





CERTIFICATE OF COMPLIANCE



This is to certify that the
QUALITY MANAGEMENT SYSTEM of

C-V-S MAKİNE SANAYİ VE TİCARET LİMİTED ŞİRKETİ.

BEŞEVLER SANAYİ SİTESİ 18. BLOK NO: 7-8-10 NİLÜFER / BURSA - TÜRKİYE

has been assessed by International Certification Services Pvt. Ltd. and registered as complying with the requirements of the following International Standard:

ISO 9001:2000

The Quality Management System applicable to:

Scope: Manufacturing Of Precision Tool Holders

HASSAS TAKIM TUTUCULARI İMALATI

Registration No. : RQ90/082
Registered Date : 13th July, 2010
Valid for : 3 years
Expiry Date : 12th July, 2013



Technical Director
International Certification Services

Accredited by Joint Accreditation System of Australia and New Zealand

Validity of this certificate is based on periodic audits of the management system defined by the above scope and is contingent upon prompt, written notification of significant changes to the management system and/or its components thereof shall be immediately communicated to ICS. Further clarifications regarding the scope of this certificate and the applicability of ISO 9001:2000 requirements may be obtained by consulting the above certification body.

International Certification Services Pvt. Ltd. E-7, Chand Society, Juhu Road, Juhu, Mumbai - 400 049, India.

Firma kurucusu ve yönetim kurulu başkanı Sn.Bayram EROĞLU, Hassas Tutucu Takım konusunda sektörde derin bir tecrübe ve bilgiye sahiptir. EROĞLU Makina bünyesinde, Üretim ve Satış departmanlarında edinmiş olduğu 25 yıllık bilgi ve birikimle 2005 yılında EROĞLU Makina'dan ayrılarak C.V.S.Makina'yı kurmuştur.

C.V.S.Makina olarak Hassas Tutucu Takım alanında sektörde yeni bir alternatif olmanın yanısıra, Özel Tutucu ve Pens imalatımızla ülkemizde bulunan ihtiyacı büyük oranda karşılamaktayız.

C.V.S.Makina 2005 yılından itibaren uzmanlık gerektiren Hassas Tutucu Takım konusunda faaliyet gösteren, değerlerine ve vizyonuna inanan, disiplinli çalışma hayatını benimsemiş bir şirket olarak yoluna devam etmektedir.

Vizyon

- ▶ Müşterilerimiz için değer yaratmak, beklentilerine kalite ve istikrarla karşılık vermek
- ▶ Ürünlerimize sahip çıkmak ve satış sonrasında da müşterilerimizin yanında olmak
- ▶ Müşterilerimizle, samimiyet ve saygınlık çerçevesinde ticaret yapmak

Misyon

- ▶ Kalitemizi yükseltip, ürün yelpazemizi genişleterek müşteri memnuniyetini arttırmak.
- ▶ Ulusal ve uluslararası piyasada iş hacmimizi genişletmek.

“ARADIĞINIZ ÇÖZÜM BURADA”





DIN 2080

Takım Tutucular
Werkzeugaufnahmen
Toolholders

7 - 19



DIN 69871 A-AD , AD/B

Takım Tutucular
Werkzeugaufnahmen
Toolholders

21 - 42



JIS B 6339 (MAS 403 BT) A-AD, AD/B

Takım Tutucular
Werkzeugaufnahmen
Toolholders

44 - 64



Yedekler
Zubehör
Accessories

66 - 87



DIN 2080

Takim Tutucular
Werkzeugaufnahmen
Toolholders



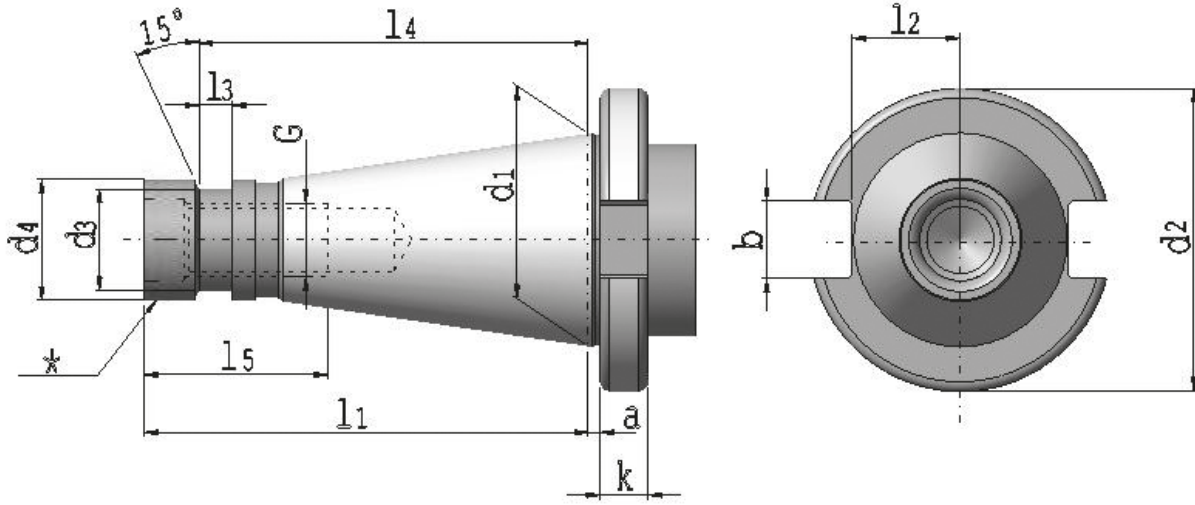

DK	d1	a	b	k	G	d2	d3	d4	L1	L2	L3	L4	L5
30	31,75	1,6	16,1	8	M12	50,0	-	17,2	68,4	16,2	-	-	24,0
40	44,45	1,6	16,1	10	M16	63,0	21,1	25,0	93,4	22,5	7,0	82,0	35,0
50	69,85	3,2	25,7	12	M24	97,5	-	39,2	126,8	35,0	-	-	50,0

Malzeme : Alaşımlı semente çeliği çekme mukavemeti min. 950 N/mm²
 Teknik özelliği : Sertlik HRC 58 ± 2 , sertlik derinliği 0,6 mm + 0,2 mm, karartılmış
 Hassasiyeti : Konik açı toleransı kalitesi DIN 2080 normuna göre AT3
 Konik Yüzey kalitesi max. 0,001 mm

Wekstoff : Legierter Einsatzstahl mit einer Zugfestigkeit im Kern von min. 950 N/mm²
 Ausführung : Einsatzgeharter HRC 58 ± 2 , Harteriefe 0,6 mm + 0,2 mm brüniert
 Genauigkeit : Kegelminkel-Toleranzqualität AT 3 nach DIN 2080
 Oberflächenrauigkeit des Kegels max. 0,001 mm

Material : Case hardened steel, tensile strength in the core min. 950 N/mm²
 Execution : Case hardened HRC 58 ± 2 , Depth of case 0,6 mm + 0,2 mm, black - finish
 Accuracy : Cone angle AT 3 according DIN 2080
 Surface roughness of cone max. 0,001 mm

Spannfutter DIN 6391 für Spannzangen DIN 6388
Collet chucks DIN 6391 for Collets DIN 6388

Sipariş No Bestell Nr. Order Nr.	DK	Kapasite Spannbereich Capacity	A	D
001.01.16	DK 30	2 - 16	50	43
001.01.25	DK 30	3 - 25	80	60
002.01.16	DK 40	2 - 16	55	43
002.01.25	DK 40	3 - 25	66	60
002.01.32	DK 40	4 - 32	95	72
003.01.25	DK 50	3 - 25	71	60
003.01.32	DK 50	4 - 32	73	72

Teslim Şekli : Kapak ile birlikte
Lieferumfang : Inkl. Spannmutter
Included : Clamping nut

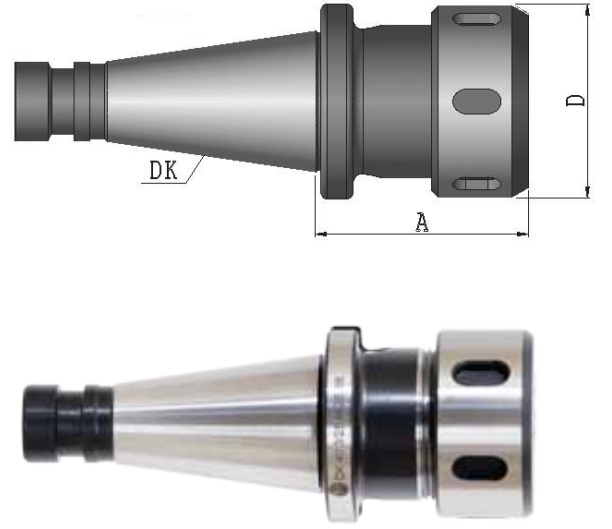

Spannfutter für Spannzangen DIN 6499 ER
Collet chucks for Collets DIN 6499 ER

Sipariş No Bestell Nr. Order Nr.	DK	Kapasite Spannbereich Capacity	A	D
001.02.16	DK 30	ER25 2 - 16	50	42
001.02.20	DK 30	ER 32 2 - 20	50	50
001.02.26	DK 30	ER 40 3 - 26	80	63
002.02.16	DK 40	ER 25 2 - 16	50	42
002.02.20	DK 40	ER 32 2 - 20	50	50
002.02.26	DK 40	ER 40 3 - 26	80	63
003.02.20	DK 50	ER 32 2 - 20	63	50
003.02.26	DK 50	ER 40 3 - 26	63	63

Teslim Şekli : Kapak ile birlikte
Lieferumfang : Inkl. Spannmutter
Included : Clamping nut

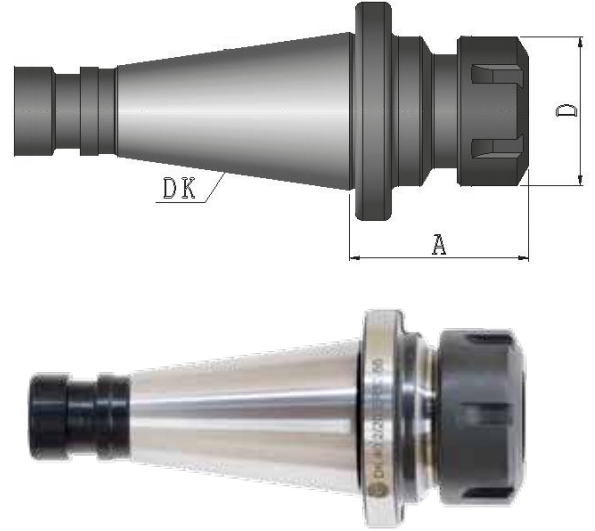

Fräseraufnahmen DIN 6359 für Zylinderschäfte DIN 1835-B
End mill holder DIN 6359 for weldon type end mills DIN 1835-B

Sipariş No Bestell Nr. Order Nr.	DK	d	A	D
001.10.06	DK 30	6	40	25
001.10.08	DK 30	8	40	28
001.10.10	DK 30	10	40	35
001.10.12	DK 30	12	40	42
001.10.14	DK 30	14	50	44
001.10.16	DK 30	16	50	48
001.10.18	DK 30	18	50	50
001.10.20	DK 30	20	63	52
002.10.06	DK 40	6	50	25
002.10.08	DK 40	8	50	28
002.10.10	DK 40	10	50	35
002.10.12	DK 40	12	50	42
002.10.14	DK 40	14	50	44
002.10.16	DK 40	16	63	48
002.10.18	DK 40	18	63	50
002.10.20	DK 40	20	63	52
002.10.25	DK 40	25	80	65
002.10.32	DK 40	32	80	72
002.10.40	DK 40	40	90	80

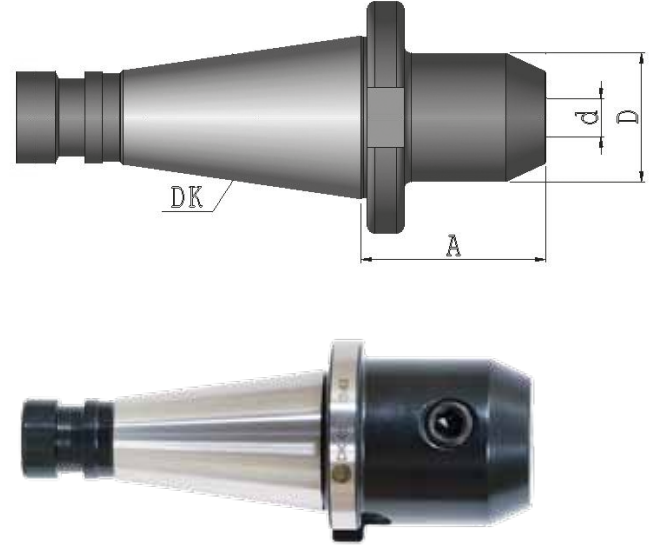

Teslim Şekli : Sıkma civatası ile birlikte
Lieferumfang : Inkl. Spannschraube
Included : Clamping screw

Hinweis : Bohrungstoleranz H4
Application : Boring tolerance H4
Açıklama : İç çap toleransı H4

Fräseraufnahmen DIN 6359 für Zylinderschäfte DIN 1835-B
End mill holder DIN 6359 for weldon type end mills DIN 1835-B

Sipariş No Bestell Nr. Order Nr.	DK	d	A	D
003.10.06	DK 50	6	63	25
003.10.08	DK 50	8	63	28
003.10.10	DK 50	10	63	35
003.10.12	DK 50	12	63	42
003.10.14	DK 50	14	63	44
003.10.16	DK 50	16	63	48
003.10.18	DK 50	18	63	50
003.10.20	DK 50	20	63	52
003.10.25	DK 50	25	80	65
003.10.32	DK 50	35	80	72
003.10.40	DK 50	40	90	80

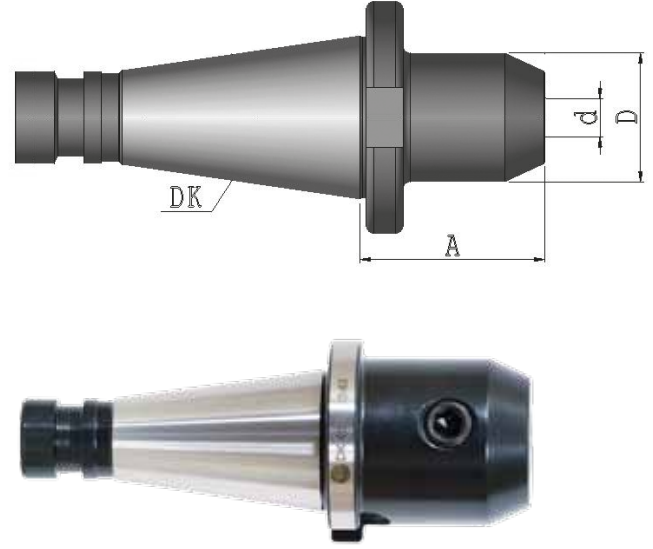

Teslim Şekli : Sıkma civatası ile birlikte
Lieferumfang : Inkl. Spannschraube
Included : Clamping screw

Hinweis : Bohrungstoleranz H4
Application : Boring tolerance H4
Açıklama : İç çap toleransı H4

Zwischenhülsen für MK mit Austreibblappen DIN 6383
Mors taper adaptor DIN 6383

Sipariş No Bestell Nr. Order Nr.	DK	MK	A	D
001.20.01	DK 30	1	50	25
001.20.02	DK 30	2	50	32
001.20.03	DK 30	3	75	40
002.20.01	DK 40	1	50	25
002.20.02	DK 40	2	50	32
002.20.03	DK 40	3	65	40
002.20.04	DK 40	4	95	48
003.20.01	DK 50	1	45	25
003.20.02	DK 50	2	60	32
003.20.03	DK 50	3	65	40
003.20.04	DK 50	4	70	48
003.20.05	DK 50	5	105	63

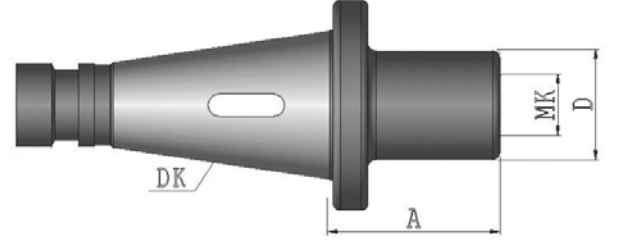

Zwischenhülsen für MK mit Anzugsgewinde DIN 6364

Mors taper adaptor for tools with morse taper shank and drawbar thread DIN 6364

Sipariş No Bestell Nr. Order Nr.	DK	MK	A	D
002.21.01	DK 40	1	50	25
002.21.02	DK 40	2	50	32
002.21.03	DK 40	3	65	40
002.21.04	DK 40	4	95	48
003.21.01	DK 50	1	60	25
003.21.02	DK 50	2	60	32
003.21.03	DK 50	3	65	40
003.21.04	DK 50	4	65	48
003.21.05	DK 50	5	120	63

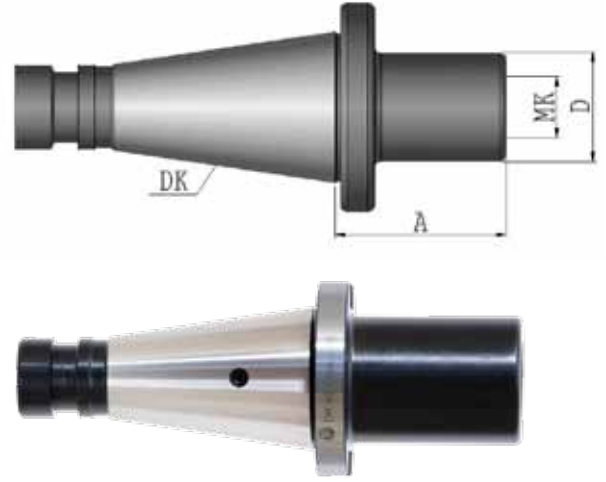

* Taşıyıcı yuvalı DIN 2201

* Mit Mitnehmerausfrassung nach DIN 2201

* With driving facilities to DIN 2201

Montaj civatası ile beraber

Lieferung erfolgt mit eingegebauter Schraube

Delivery with build-in screw

Zwischenhülsen / Reduzierhülsen
Reduction Sleeves

Sipariş No Bestell Nr. Order Nr.	DK	DK ₁	A	D
002.23.40	DK 40	DK-40	100	63
003.23.40	DK 50	DK-40	50	70
003.23.50	DK 50	DK-50	125	97

DIN 2080 Konik çektirme civatası ile birlikte
Lieferung erfolgt mit einegebauter Schraube für
Werkzeuge mit gekürztem Steilkegel
Schraube für DIN 2080 Werkzeuge beiliegend
Including a built-in screw for shortened tape tools,
Additional one screw for DIN 2080 tools

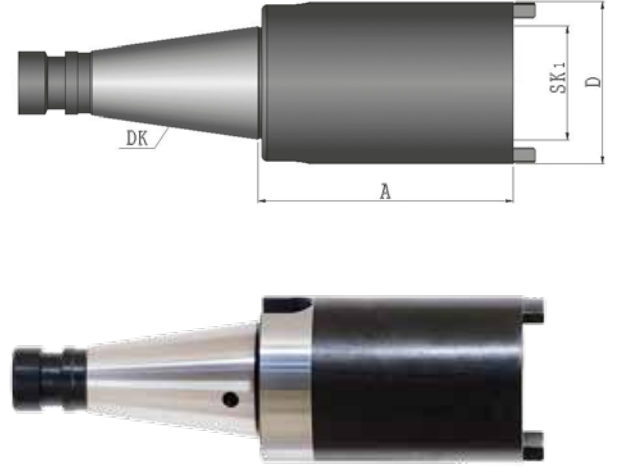

Kombi - Aufsteckfräserdorne DIN 6358
Combi shell mill holder DIN 6358

Sipariş No Bestell Nr. Order Nr.	DK	d	A	L	D
001.30.16	DK 30	16	35	17	32
001.30.22	DK 30	22	35	19	40
001.30.27	DK 30	27	35	21	48
001.30.32	DK 30	32	50	24	58
002.30.16	DK 40	16	52	17	32
002.30.22	DK 40	22	52	19	40
002.30.27	DK 40	27	52	21	48
002.30.32	DK 40	32	52	24	58
002.30.40	DK 40	40	52	27	70
003.30.16	DK 50	16	55	17	32
003.30.22	DK 50	22	55	19	40
003.30.27	DK 50	27	55	21	48
003.30.32	DK 50	32	55	24	58
003.30.40	DK 50	40	55	27	70

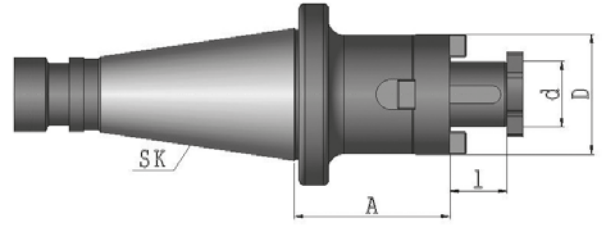

Teslim Şekli : Alın civatası, kaması ve tırnaklı pulu ile birlikte
Lieferumfang : Inklusive Paßfeder, Mitnehmerring und Fräseranzugsschraube
Included : Milling cutter retention, screw, drive key with threaded hole
for push-out screw, combination drive ring

Quernut - Aufssteckdorme DIN 6357 mit vergrößertem Bunddurchmesser
Shell mill holder DIN 6357 for cutters with driving slot

Sipariş No Bestell Nr. Order Nr.	DK	d	A	L	D
002.31.16	DK 40	16	30	17	38
002.31.22	DK 40	22	30	19	48
002.31.27	DK 40	27	30	21	58
002.31.32	DK 40	32	30	24	78
002.31.40	DK 40	40	30	27	88
003.31.16	DK 50	16	35	17	38
003.31.22	DK 50	22	35	19	48
003.31.27	DK 50	27	35	21	58
003.31.32	DK 50	32	40	24	78
003.31.40	DK 50	40	33	27	88
003.31.60	DK 50	60	55	40	128

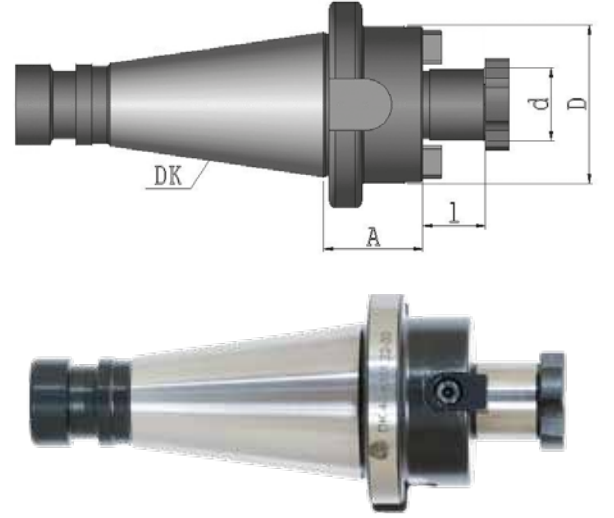

Teslim Şekli : Alın civatası ve kaması ile birlikte
Lieferumfang : Inkl. Mitnehmerring und Fräseranzugsschraube
Included : Drive and cruciform screw

Bohrfutteraufnahme DIN 238
Drill chuck adaptor DIN 238

Sipariş No Bestell Nr. Order Nr.	DK	d	A	D
001.32.12	DK 30	B12	13,5	18,5
001.32.16	DK 30	B16	15,5	24
002.32.12	DK 40	B12	15	18,5
002.32.16	DK 40	B16	17	24
002.32.18	DK 40	B18	17	32
003.32.16	DK 50	B16	20	24
003.32.18	DK 50	B18	20	32

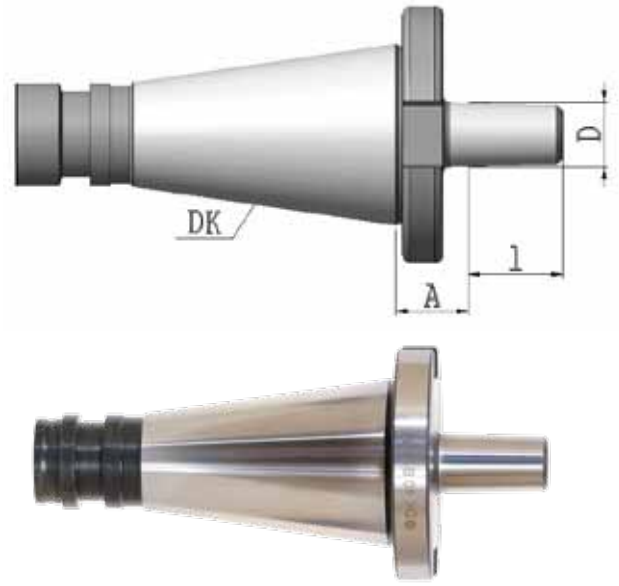

NC tipi mandren malafası komple sağ ve sol dönüşlü

DIN 2080

NC -Bohrfutter für Rechts und Linkslauf
NC - Drill chucks for left and right rotation

Sipariş No Bestell Nr. Order Nr.	DK	Kapitesi Spannbereich Capacity	d	A	D
001.32.13	DK 30	1,0 - 13		97	51,5
002.32.13	DK 40	1,0 - 13		100	51,5
002.32.16	DK 40	3,0 - 16		116	58
003.32.13	DK 50	1,0 - 13		90	51,5
003.32.16	DK 50	3,0 - 16		120	58

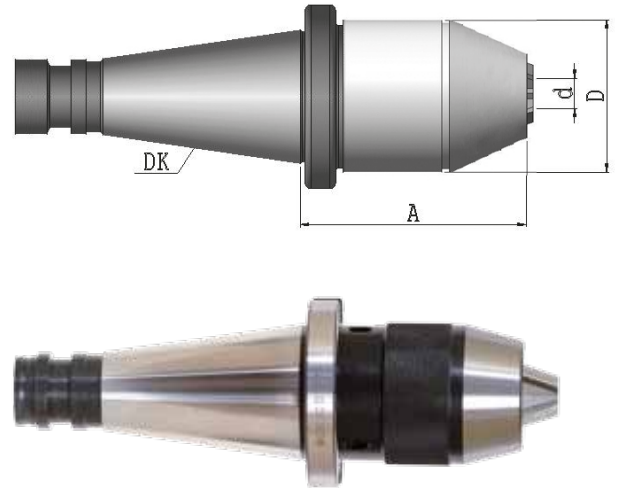

Teslim Şekli : Anahtarı ile birlikte
Lieferumfang : Inkl. Spannschlüssel
Included : Wrench

Gewindeschneid - Schnellwechselfutter mit Längenausgleich auf Druck un Zug
Quick-change tapping chucks with length compensation

Sipariş No Bestell Nr. Order Nr.	DK	Kapatesi Spannbereich Capacity	d	A	D	C	T
002.22.12	DK 40	M3-M14	19	61	38	7	7
002.22.24	DK 40	M5-M22	31	99	54	12	12
003.22.12	DK 50	M3-M14	19	61	38	7	7
003.22.24	DK 50	M5-M22	31	82	54	12	12

Teknik özelliği : Bilya kafesli.
Ausführung : Mit Kugelführungsbuchse
Version : With ball retainer

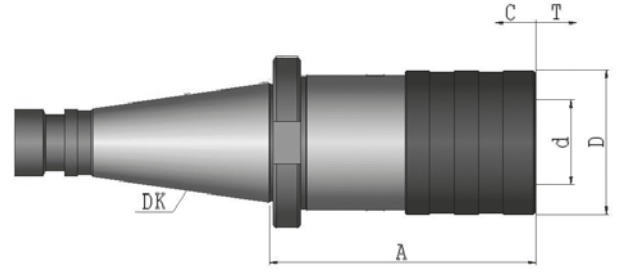

Bohrstangenrohlinge zur Anfertigung von Sonderwerkzeugen
Boring bar blanks for the production of special tools

Sipariş No Bestell Nr. Order Nr.	DK	A	D
002.33.63	DK 40	250	63
003.33.97	DK 50	315	97

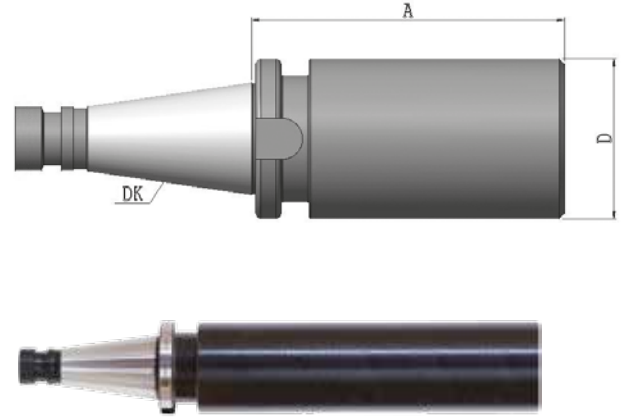

- Teknik özelliği : Konik ve Flanş kısmı sertleştirilmiş ve taşlanmıştır.
Bara kısmı işlenebilir yumuşaklıktadır.
- Ausführung : Steilkegel und Bund gehärtet und geschliffen,
Schaft weich zure weiteren Bear beitung.
- Version : Cone and flange hardened and grinded.
Soft body for later processing.

Fener mili kontrol mastarı

Kontrolldorne
Test arbors

Sipariş No Bestell Nr. Order Nr.	DK	A	D
001.34.32	DK 30	200	32
002.34.40	DK 40	300	40
003.34.50	DK 50	300	50

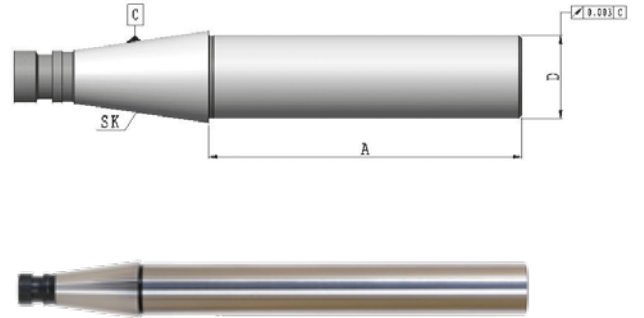

- Açıklama : Tezgahları devreye alırken ISO Normu R 230 sisteminde uygunluğunu kontrol etmek için
- Verwendung : Zur Abnahme von Werkzeugmaschinen gemäß ISO-Empfehlung R 230
- Application : For acceptance tests of machine tools in accordance with ISO-recommendation R 230
- Teslim Şekli : Sandığı ve Kontrol Sertifikasıyla birlikte
- Lieferung : Im Holzkasten mit Prüfprotokoll
- Verwendung : Zur Abnahme von Werkzeugmaschinen gemäß ISO-Empfehlung R 230
- Application : For acceptance tests of machine tools in accordance with ISO-recommendation R 230

DIN 69871 A-AD , AD/B

Takim Tutucular
Werkzeugaufnahmen
Toolholders



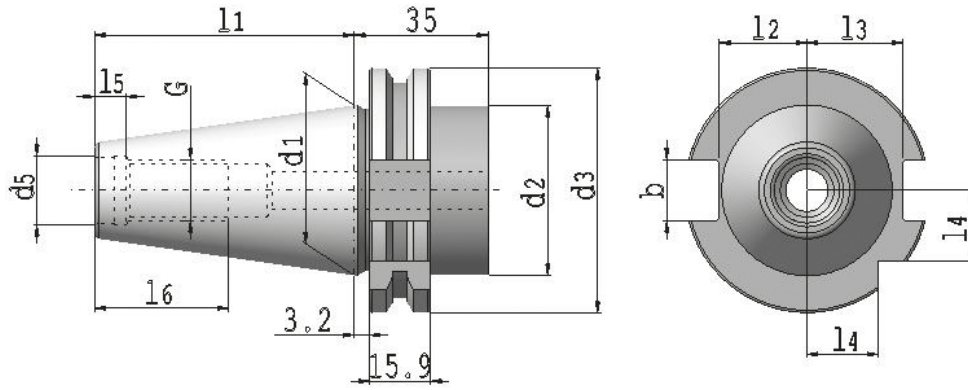

SK	d1	G	d5	d2	d3	L1	L2	L3	L4	L5	L6	d6	e	b
30	31,75	M12	13	45	50,00	50,0	16,4	19,0	15,0	5,5	24	4	21	16,1
40	44,45	M16	17	50	63,55	63,0	22,8	25,0	18,5	8,2	32	4	27	16,1
50	69,85	M24	25	80	97,50	97,5	35,5	37,7	30,0	11,5	47	6	42	27,7

Merkezde ve Flanşta su delikleri vardır
Mit innerer Kühlmittelzufuhr
With internal coolant

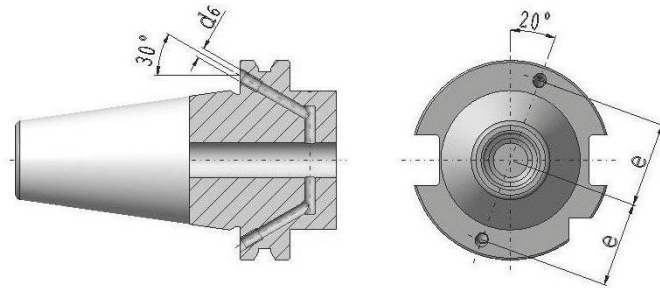

Malzeme : Alaşımlı sement çeliği çekme mukavemeti min. 950 N/mm²
Teknik özelliği : Sertlik HRC 58 ± 2 , sertlik derinliği 0,6 mm + 0,2 mm, karartılmış
Hassasiyeti : Konik açı toleransı kalitesi DIN 2080 normuna göre AT3
Konik Yüzey kalitesi max. 0,001 mm

Werkstoff : Legierter Einsatzstahl mit einer Zugfestigkeit im Kern von min. 950 N/mm²
Ausführung : Einsatzgeharter HRC 58 ± 2 , Harteriefe 0,6 mm + 0,2 mm brüniert
Genauigkeit : Kegelwinkel-Toleranzqualität AT 3 nach DIN 2080
Oberflächenrauigkeit des Kegels max. 0,001 mm

Material : Case hardened steel, tensile strength in the core min. 950 N/mm²
Execution : Case hardened HRC 58 ± 2 , Depth of case 0,6 mm + 0,2 mm, black - finish
Accuracy : Cone angle AT 3 according DIN 2080
Surface roughness of cone max. 0,001 mm

Spannfutter DIN 6391 für Spannzangen DIN 6388
Collet chucks DIN 6391 for Collets DIN 6388

FORM AD

Sipariş No Bestell Nr. Order Nr.	SK	Kapasite Spannbereich Capacity	A	D
005.01.16	SK 30	2 - 16	60	43
005.01.25	SK 30	2 - 25	80	60
006.01.16	SK 40	2 - 16	70	43
006.01.25	SK 40	2 - 25	70	60
006.01.32	SK 40	2 - 32	90	72
007.01.25	SK 50	2 - 25	70	60
007.01.32	SK 50	2 - 32	80	72

Teslim Şekli : Kapak ile birlikte
Lieferumfang : Inkl. Spannmutter
Included : Clamping nut

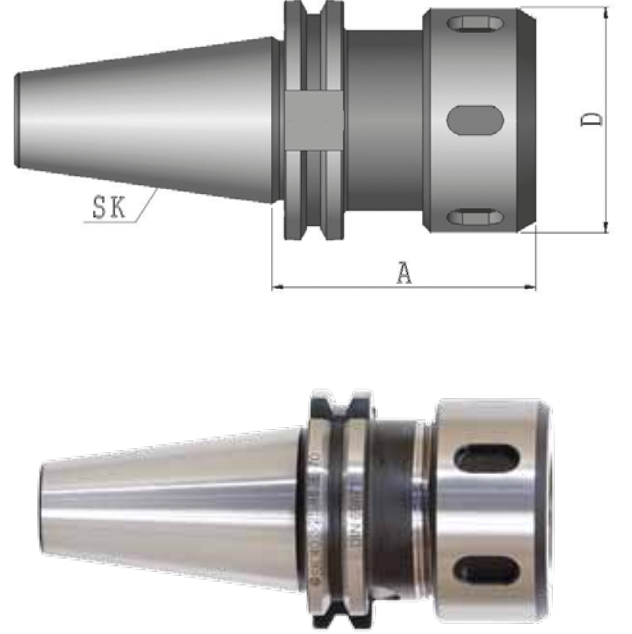

Spannfutter DIN 6391 für Spannzangen DIN 6388
Collet chucks DIN 6391 for Collets DIN 6388

FORM AD/B

Sipariş No Bestell Nr. Order Nr.	SK	Kapasite Spannbereich Capacity	A	D
016.01.16	SK 40	2 - 16	70	43
016.01.25	SK 40	3 - 25	70	60
016.01.32	SK 40	4 - 32	90	72
017.01.25	SK 50	3 - 25	70	60
017.01.32	SK 50	4 - 32	80	72

Teslim Şekli : Kapak ile birlikte
Lieferumfang : Inkl. Spannmutter
Included : Clamping nut



Spannfutter für Spannzangen DIN 6499 ER
Collet chucks for Collets DIN 6499 ER

FORM AD

Sipariş No Bestell Nr. Order Nr.	SK	Kapasite Spannbereich Capacity	A	D
005.02.10	SK 30	ER 16 1 - 10	70	32
005.02.10-100	SK 30	ER 16 1 - 10	100	32
005.02.16	SK 30	ER 25 2 - 16	70	42
005.02.16-100	SK 30	ER 25 2 - 16	100	42
005.02.20	SK 30	ER 32 2 - 20	70	50
005.02.20-100	SK 30	ER 32 2 - 20	100	50
005.02.26	SK 30	ER 40 3 - 26	70	63
006.02.10	SK 40	ER 16 1 - 10	63	32
006.02.10-100	SK 40	ER 16 1 - 10	100	32
006.02.10-160	SK 40	ER 16 1 - 10	160	32
006.02.16	SK 40	ER 25 2 - 16	60	42
006.02.16-100	SK 40	ER 25 2 - 16	100	42
006.02.16-160	SK 40	ER 25 2 - 16	160	42
006.02.20	SK 40	ER 32 2 - 20	70	50
006.02.20-100	SK 40	ER 32 2 - 20	100	50
006.02.20-160	SK 40	ER 32 2 - 20	160	50
006.02.26	SK 40	ER 40 3 - 26	80	63
006.02.26-100	SK 40	ER 40 3 - 26	100	63
006.02.26-160	SK 40	ER 40 3 - 26	160	63
007.02.10	SK 50	ER 16 1 - 10	63	32
007.02.10-100	SK 50	ER 16 1 - 10	100	32
007.02.10-160	SK 50	ER 16 1 - 10	160	32
007.02.16	SK 50	ER 25 2 - 16	60	42
007.02.16-100	SK 50	ER 25 2 - 16	100	42
007.02.16-160	SK 50	ER 25 2 - 16	160	42
007.02.20	SK 50	ER 32 2 - 20	70	50
007.02.20-100	SK 50	ER 32 2 - 20	100	50
007.02.20-160	SK 50	ER 32 2 - 20	160	50
007.02.26	SK-50	ER 40 3 - 26	80	63
007.02.26-100	SK-50	ER 40 3 - 26	100	63
007.02.26-160	SK 50	ER 40 3 - 26	160	63

Teslim Şekli : Kapak ile birlikte
Lieferumfang : Inkl. Spannmutter
Included : Clamping nut



Spannfutter für Spannzangen DIN 6499 ER
Collet chucks for Collets DIN 6499 ER

FORM AD/B

Sipariş No Bestell Nr. Order Nr.	SK	Kapasite Spannbereich Capacity	A	D
016.02.10	SK 40	ER 16 1 - 10	63	32
016.02.10-100	SK 40	ER 16 1 - 10	100	32
016.02.10-160	SK 40	ER 16 1 - 10	160	32
016.02.16	SK 40	ER 25 2 - 16	60	42
016.02.16-100	SK 40	ER 25 2 - 16	100	42
016.02.16-160	SK 40	ER 25 2 - 16	160	42
016.02.20	SK 40	ER 32 2 - 20	70	50
016.02.20-100	SK 40	ER 32 2 - 20	100	50
016.02.20-160	SK 40	ER 32 2 - 20	160	50
016.02.26	SK 40	ER 40 3 - 26	80	63
016.02.26-100	SK 40	ER 40 3 - 26	100	63
016.02.26-160	SK 40	ER 40 3 - 26	160	63
017.02.10	SK 50	ER 16 1 - 10	63	32
017.02.10-100	SK 50	ER 16 1 - 10	100	32
017.02.10-160	SK 50	ER 16 1 - 10	160	32
017.02.16	SK 50	ER 25 2 - 16	60	42
017.02.16-100	SK 50	ER 25 2 - 16	100	42
017.02.16-160	SK 50	ER 25 2 - 16	160	42
017.02.20	SK 50	ER 32 2 - 20	70	50
017.02.20-100	SK 50	ER 32 2 - 20	100	50
017.02.20-160	SK 50	ER 32 2 - 20	160	50
017.02.26	SK 50	ER 40 3 - 26	80	63
017.02.26-100	SK 50	ER 40 3 - 26	100	63
017.02.26-160	SK 50	ER 40 3 - 26	160	63

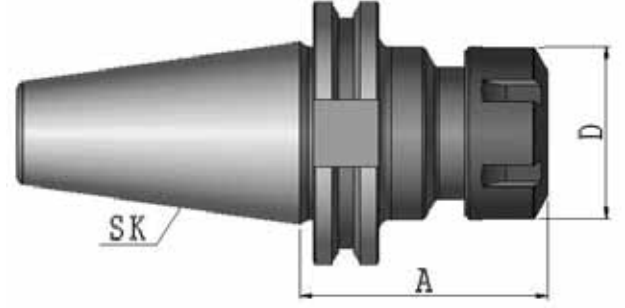

Teslim Şekli : Kapak ile birlikte
Lieferumfang : Inkl. Spannmutter
Included : Clamping nut

Präzisionskraftspannfutter
Precision Milling Chuck

FORM AD

Sipariş No Bestell Nr. Order Nr.	SK	Kapatesi Spannbereich Capacity	d	A	D
006.03.25	SK 40	CKS 25 6 - 25	25	95	58
006.03.32	SK 40	CKS 32 6 - 32	32	95	68
007.03.25	SK 50	CKS 25 6 - 25	25	95	58
007.03.32	SK 50	CKS 32 6 - 32	32	105	68

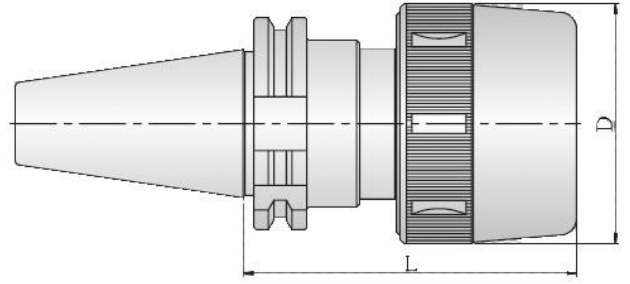

Präzisionskraftspannfutter satz im Koffer
Precision Milling Chuck set in box

FORM AD

Sipariş No Bestell Nr. Order Nr.	SK	Kapatesi Spannbereich Capacity	Pens Adeti Spannzangen Stk. Collet Psc.	A
006.53.25	SK 40	CKS 25 6 - 25	6-8-10-12-16-20	95
006.53.32	SK 40	CKS 32 6 - 32	6-8-10-12-16-20-25	95
007.53.25	SK 50	CKS 25 6 - 25	6-8-10-12-16-20	95
007.53.32	SK 50	CKS 32 6 - 32	6-8-10-12-16-20-25	105



Teslim Şekli : Takım, pensleri ve anahtarıyla birlikte
Lieferumfang : Spannfüter, inkl. Spannzangen mit Schlüssel
Included : Collet chuck with collets and wrench

Fräseraufnahmen DIN 6359 für Zylinderschäfte DIN 1835-B
End mill holder DIN 6359 for weldon type end mills BIN 1835-B

FORM AD

Sipariş No Bestell Nr. Order Nr.	SK	d	A	D
005.10.06	SK 30	6	50	25
005.10.08	SK 30	8	50	28
005.10.10	SK 30	10	50	35
005.10.12	SK 30	12	50	42
005.10.14	SK 30	14	63	44
005.10.16	SK 30	16	63	48
005.10.18	SK 30	18	63	50
005.10.20	SK 30	20	70	52

Hinweis : Bohrungstoleranz H4
Application : Boring tolerance H4
Açıklama : İç çap toleransı H4

Teslim Şekli : Sıkma civatası ile birlikte
Lieferumfang : Inkl. Spannschraube
Included : Clamping screw

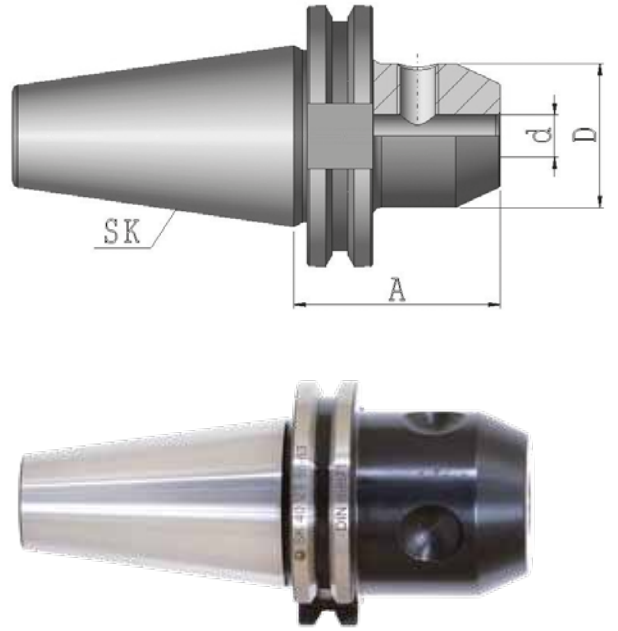



Fräseraufnahmen DIN 6359 für Zylinderschäfte DIN 1835-B
End mill holder DIN 6359 for weldon type end mills BIN 1835-B

FORM AD

Sipariş No Bestell Nr. Order Nr.	SK	d	A	D
006.10.06	SK 40	6	50	25
006.10.06-100	SK 40	6	100	25
006.10.06-160	SK 40	6	160	25
006.10.08	SK 40	8	50	28
006.10.08-100	SK 40	8	100	28
006.10.08-160	SK 40	8	160	28
006.10.10	SK 40	10	50	35
006.10.10-100	SK 40	10	100	35
006.10.10-160	SK 40	10	160	35
006.10.12	SK 40	12	50	42
006.10.12-100	SK 40	12	100	42
006.10.12-160	SK 40	12	160	42
006.10.14	SK 40	14	50	44
006.10.14-100	SK 40	14	100	44
006.10.14-160	SK 40	14	160	44
006.10.16	SK 40	16	35	45
006.10.16-35	SK 40	16	63	48
006.10.16-100	SK 40	16	100	48
006.10.16-160	SK 40	16	160	48
006.10.18	SK 40	18	35	50
006.10.18-100	SK 40	18	100	50
006.10.18-160	SK 40	18	160	50
006.10.20	SK 40	20	35	45
006.10.20-35	SK 40	20	63	52
006.10.20-100	SK 40	20	100	52
006.10.20-160	SK 40	20	160	52
006.10.25	SK 40	25	35	50
006.10.25-35	SK 40	25	100	65
006.10.25-160	SK 40	25	160	65
006.10.32	SK 40	32	65	50
006.10.32-65	SK 40	32	100	72
006.10.32-160	SK 40	32	160	72
006.10.40	SK 40	40	120	80

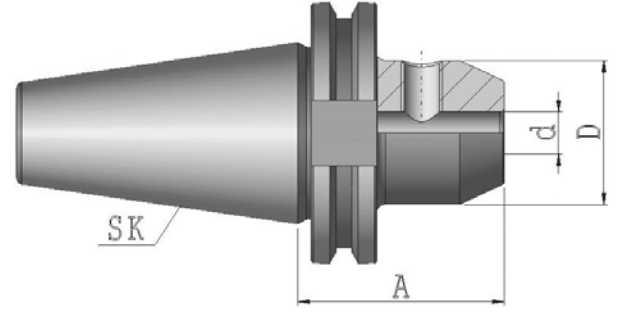

Teslim Şekli : Sıkma civatası ile birlikte
Lieferumfang : Inkl. Spannschraube
Included : Clamping screw

Hinweis : Bohrungstoleranz H4
Application : Boring tolerance H4
Açıklama : İç çap toleransı H4

Fräseraufnahmen DIN 6359 für Zylinderschäfte DIN 1835-B
End mill holder DIN 6359 for weldon type end mills BIN 1835-B

FORM AD

Sipariş No Bestell Nr. Order Nr.	SK	d	A	D
007.10.06	SK 50	6	63	25
007.10.06-100	SK 50	6	100	25
007.10.06-160	SK 50	6	160	25
007.10.08	SK 50	8	63	28
007.10.08-100	SK 50	8	100	28
007.10.08-160	SK 50	8	160	28
007.10.10	SK 50	10	63	35
007.10.10-100	SK 50	10	100	35
007.10.10-160	SK 50	10	160	35
007.10.12	SK 50	12	63	42
007.10.12-100	SK 50	12	100	42
007.10.12-160	SK 50	12	160	42
007.10.14	SK 50	14	63	44
007.10.14-100	SK 50	14	100	44
007.10.14-160	SK 50	14	160	44
007.10.16	SK 50	16	63	48
007.10.16-35	SK 50	16	100	48
007.10.16-100	SK 50	16	160	48
007.10.16-160	SK 50	16	63	50
007.10.18	SK 50	18	100	50
007.10.18-100	SK 50	18	160	50
007.10.18-160	SK 50	18	63	52
007.10.20	SK 50	20	100	52
007.10.20-100	SK 50	20	160	52
007.10.20-160	SK 50	20	80	65
007.10.22	SK 50	22	120	65
007.10.25	SK 50	25	160	65
007.10.25-160	SK 50	25	100	72
007.10.32	SK 50	32	160	72
007.10.32-160	SK 50	32	100	80
007.10.40	SK 50	40	160	80

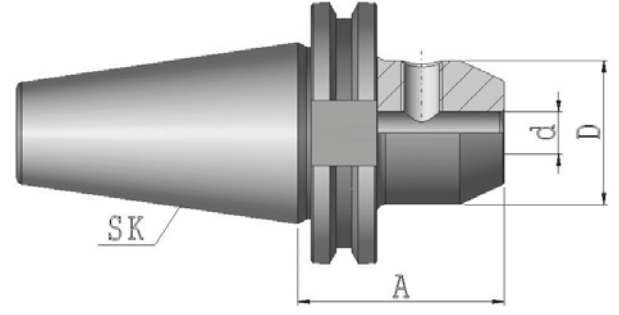

Teslim Şekli : Sıkma civatası ile birlikte
Lieferumfang : Inkl. Spannschraube
Included : Clamping screw

Hinweis : Bohrungstoleranz H4
Application : Boring tolerance H4
Açıklama : İç çap toleransı H4

Fräseraufnahmen DIN 6359 für Zylinderschäfte DIN 1835-B
End mill holder DIN 6359 for weldon type end mills BIN 1835-B

FORM AD/B

Sipariş No Bestell Nr. Order Nr.	SK	d	A	D
016.10.06	SK 40	6	50	25
016.10.06-100	SK 40	6	100	25
016.10.06-160	SK 40	6	160	25
016.10.08	SK 40	8	50	28
016.10.08-100	SK 40	8	100	28
016.10.08-160	SK 40	8	160	28
016.10.10	SK 40	10	50	35
016.10.10-100	SK 40	10	100	35
016.10.10-160	SK 40	10	160	35
016.10.12	SK 40	12	50	42
016.10.12-100	SK 40	12	100	42
016.10.12-160	SK 40	12	160	42
016.10.14	SK 40	14	50	44
016.10.14-100	SK 40	14	100	44
016.10.14-160	SK 40	14	160	44
016.10.16	SK 40	16	63	48
016.10.16-100	SK 40	16	100	48
016.10.16-160	SK 40	16	160	48
016.10.18	SK-40	18	63	50
016.10.18-100	SK 40	18	100	50
016.10.18-160	SK 40	18	160	50
016.10.20	SK 40	20	63	52
016.10.20-100	SK 40	20	100	52
016.10.20-160	SK 40	20	160	52
016.10.25	SK 40	25	100	65
016.10.25-160	SK 40	25	160	65
016.10.32	SK 40	32	100	72
016.10.32-160	SK 40	32	160	72
016.10.40	SK 40	40	120	80

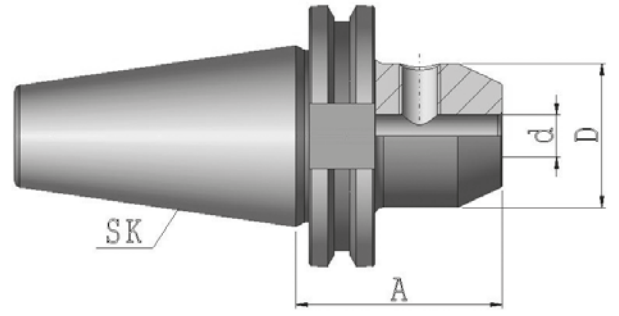

Teslim Şekli : Sıkma civatası ile birlikte
Lieferumfang : Inkl. Spanschraube
Included : Clamping screw

Hinweis : Bohrungstoleranz H4
Application : Boring tolerance H4
Açıklama : İç çap toleransı H4

Fräseraufnahmen DIN 6359 für Zylinderschäfte DIN 1835-B
End mill holder DIN 6359 for weldon type end mills BIN 1835-B

FORM AD/B

Sipariş No Bestell Nr. Order Nr.	SK	d	A	D
017.10.06	SK 50	6	63	25
017.10.06-100	SK 50	6	100	25
017.10.06-160	SK 50	6	160	25
017.10.08	SK 50	8	63	28
017.10.08-100	SK 50	8	100	28
017.10.08-160	SK 50	8	160	28
017.10.10	SK 50	10	63	35
017.10.10-100	SK 50	10	100	35
017.10.10-160	SK 50	10	160	35
017.10.12	SK 50	12	63	42
017.10.12-100	SK 50	12	100	42
017.10.12-160	SK 50	12	160	42
017.10.14	SK 50	14	63	44
017.10.14-100	SK 50	14	100	44
017.10.14-160	SK 50	14	160	44
017.10.16	SK 50	16	63	48
017.10.16-100	SK 50	16	100	48
017.10.16-160	SK 50	16	160	48
017.10.18	SK 50	18	63	50
017.10.18-100	SK 50	18	100	50
017.10.18-160	SK 50	18	160	50
017.10.20	SK 50	20	63	52
017.10.20-100	SK 50	20	100	52
017.10.20-160	SK 50	20	160	52
017.10.25	SK 50	25	80	65
017.10.25-160	SK 50	25	160	65
017.10.32	SK 50	32	100	72
017.10.32-160	SK 50	32	160	72
017.10.40	SK 50	40	100	80

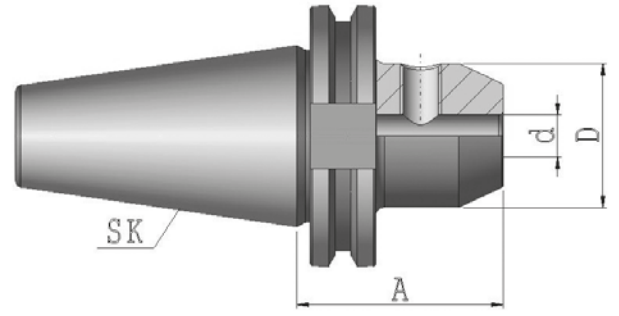

Teslim Şekli : Sıkma civatası ile birlikte
Lieferumfang : Inkl. Spannschraube
Included : Clamping screw

Hinweis : Bohrungstoleranz H4
Application : Boring tolerance H4
Açıklama : İç çap toleransı H4

Zwischenhülsen für MK mit Austreibblappen DIN 6383
Morse taper adaptor DIN 6383

FORM AD/B

Sipariş No Bestell Nr. Order Nr.	SK	MK	A	D
005.20.01	SK 30	1	50	25
005.20.02	SK 30	2	65	32
005.20.03	SK 30	3	80	40
006.20.01	SK 40	1	50	25
006.20.02	SK 40	2	50	32
006.20.03	SK 40	3	70	40
006.20.04	SK 40	4	95	48
007.20.01	SK 50	1	45	25
007.20.02	SK 50	2	60	32
007.20.03	SK 50	3	65	40
007.20.04	SK 50	4	95	48
007.20.05	SK 50	5	105	63

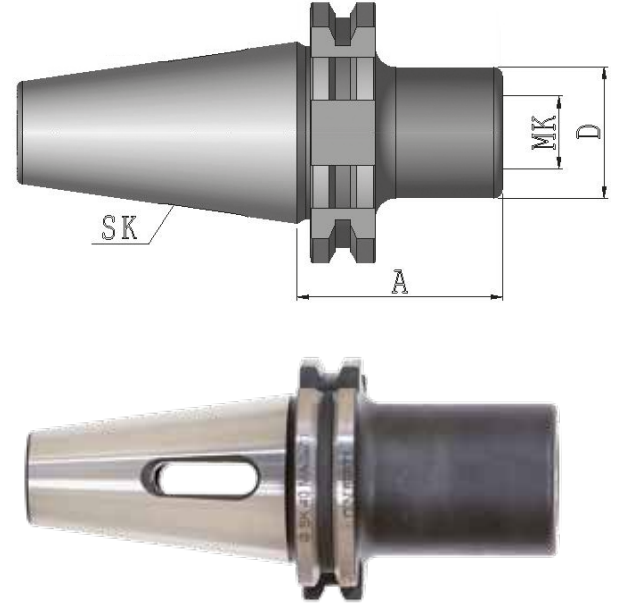

Zwischenhülsen für MK mit Anzugsgewinde DIN 6364

Morse adaptor for tools with morse taper shank and drawbar thread DIN 6364

FORM A

Sipariş No Bestell Nr. Order Nr.	SK	MK	A	D
006.21.01	SK 40	1	50	25
006.21.02	SK 40	2	50	32
006.21.03	SK 40	3	70	40
006.21.04	SK 40	4	95	48
006.21.04-A	SK 40	4	110	63
007.21.01	SK 50	1	45	25
007.21.02	SK 50	2	60	32
007.21.03	SK 50	3	65	40
007.21.04	SK 50	4	70	48
007.21.05	SK 50	5	100	63

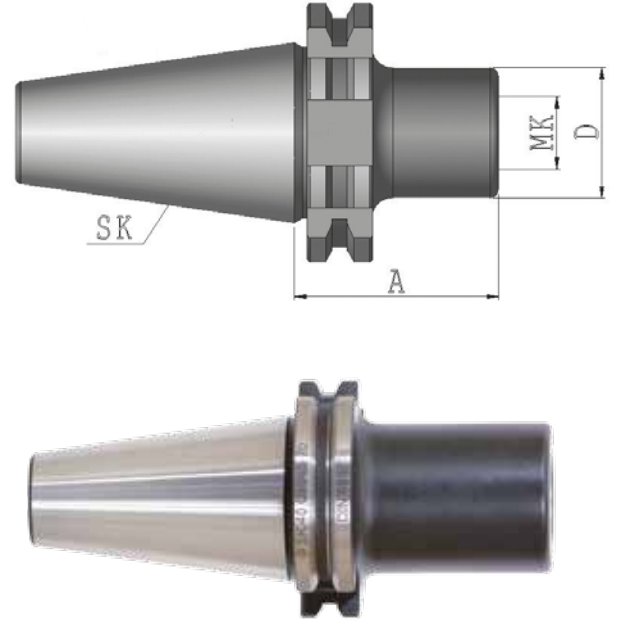

* Taşıyıcı yuvalı DIN 2201

* Mit Mitnehmerausfrassung nach DIN 2201

* With driving facilities to DIN 2201

Montaj civatası ile beraber

Lieferung erfolgt mit einegebauter Schraube

Delivery with build-in screw

Zwischenhülsen / Reduzierhülsen
Reduction Sleeves

FORM A

Sipariş No Bestell Nr. Order Nr.	SK	SK ₁	A	D
006.23.40	SK 40	SK-40	100	63
007.23.50	SK 50	SK-40	70	70
007.23.50	SK 50	SK-50	120	97

DIN 2080 Konik çektirme civatası ile birlikte
Lieferung erfolgt mit einegebauter Schraube für
Werkzeuge mit gekürztem Steilkegel
Schraube für DIN 2080 Werkzeuge beiliegend
Including a built-in screw for shortened tape tools,
Additional one screw for DIN 2080 tools

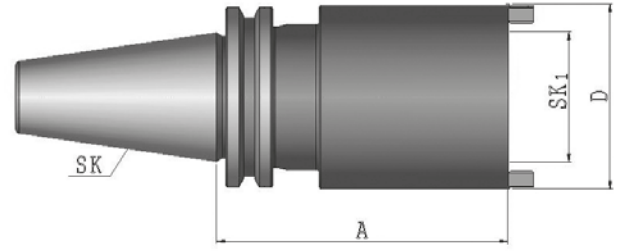

Kombi - Aufsteckfräserdorne DIN 6358
Combi shell mill holder DIN 6358

FORM AD

Sipariş No Bestell Nr. Order Nr.	SK	d	A	L1	D
005.30.16	SK 30	16	50	17	32
005.30.22	SK 30	22	50	19	40
005.30.27	SK 30	27	55	21	48
005.30.32	SK 30	32	60	24	58
006.30.16	SK 40	16	55	17	32
006.30.16-100	SK 40	16	100	17	32
006.30.22	SK 40	22	55	19	40
006.30.22-100	SK 40	22	100	19	40
006.30.27	SK 40	27	55	21	48
006.30.27-100	SK 40	27	100	21	48
006.30.32	SK 40	32	60	24	58
006.30.32-100	SK 40	32	100	24	58
006.30.40	SK 40	40	60	27	70
006.30.40-100	SK 40	40	100	27	70
007.30.16	SK 50	16	55	17	32
007.30.16-100	SK 50	16	100	17	32
007.30.22	SK 50	22	55	19	40
007.30.22-100	SK 50	22	100	19	40
007.30.27	SK 50	27	55	21	48
007.30.27-100	SK 50	27	100	21	48
007.30.32	SK 50	32	55	24	58
007.30.32-100	SK 50	32	100	24	58
007.30.40	SK 50	40	55	27	70
007.30.40-100	SK 50	40	100	27	70

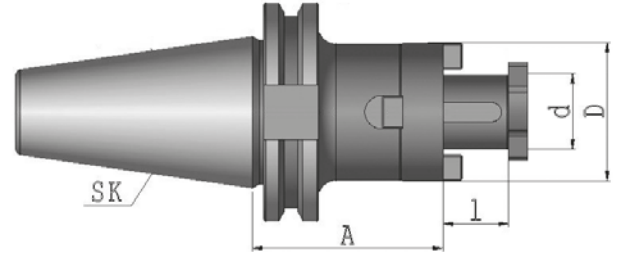

Teslim Şekli : Alın civatası, kaması ve tırnaklı pulu ile birlikte
Lieferumfang : Inklusive Paßfeder, Mitnehmerring und Fräseranzugsschraube
Included : Milling cutter retention, screw, drive key with threaded hole
for push-out screw, combination drive ring

Kombi - Aufsteckfräserdorne DIN 6358
Combi shell mill holder DIN 6358

FORM AD/B

Sipariş No Bestell Nr. Order Nr.	SK	d	A	L1	D
016.30.16	SK 40	16	55	17	32
016.30.16-100	SK 40	16	100	17	32
016.30.22	SK 40	22	55	19	40
016.30.22-100	SK 40	22	100	19	40
016.30.27	SK 40	27	55	21	48
016.30.27-100	SK 40	27	100	21	48
016.30.32	SK 40	32	60	24	58
016.30.32-100	SK 40	32	100	24	58
016.30.40	SK 40	40	60	27	70
016.30.40-100	SK 40	40	100	27	70
017.30.16	SK 50	16	55	17	32
017.30.16-100	SK 50	16	100	17	32
017.30.22	SK 50	22	55	19	40
017.30.22-100	SK 50	22	100	19	40
017.30.27	SK 50	27	55	21	48
017.30.27-100	SK 50	27	100	21	48
017.30.32	SK 50	32	55	24	58
017.30.32-100	SK 50	32	100	24	58
017.30.40	SK 50	40	55	27	70
017.30.40-100	SK 50	40	100	27	70

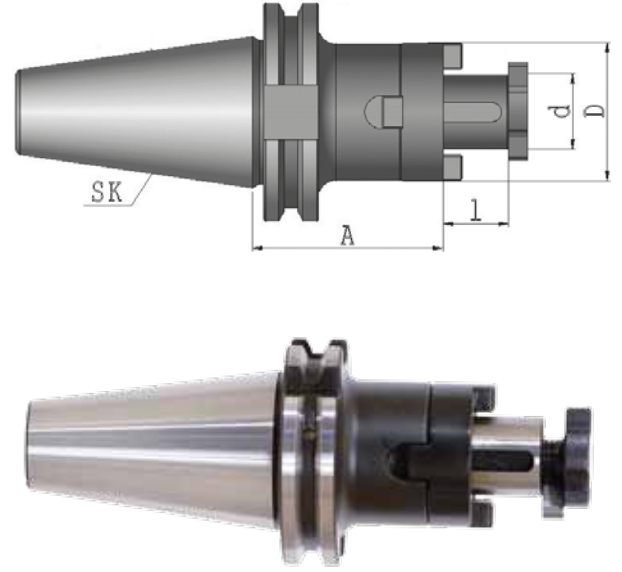

Teslim Şekli : Alın civatası, kaması ve tırnaklı pulu ile birlikte
Lieferumfang : Inklusive Paßfeder, Mitnehmerring und Fräseranzugschraube
Included : Milling cutter retention, screw, drive key with threaded hole
for push-out screw, combination drive ring

Quernut - Aufsteckdorne DIN 6357 mit vergrößertem Bunddurchmesser
Shell mill holder DIN 6357 for cutters with driving slot

FORM A

Sipariş No Bestell Nr. Order Nr.	SK	d	A	L1	D
005.31.16	SK 30	16	40	17	38
005.31.22	SK 30	22	40	19	48
005.31.27	SK 30	27	50	21	58
005.31.32	SK 30	32	50	24	78
006.31.16	SK 40	16	35	17	38
006.31.22	SK 40	22	35	19	48
006.31.27	SK 40	27	40	21	58
006.31.32	SK 40	32	50	24	78
006.31.40	SK 40	40	50	27	88
007.31.16	SK 50	16	35	17	38
007.31.22	SK 50	22	35	19	48
007.31.27	SK 50	27	40	21	58
007.31.32	SK 50	32	50	24	78
007.31.40	SK 50	40	50	27	88
007.31.60	SK 50	60	70	40	128

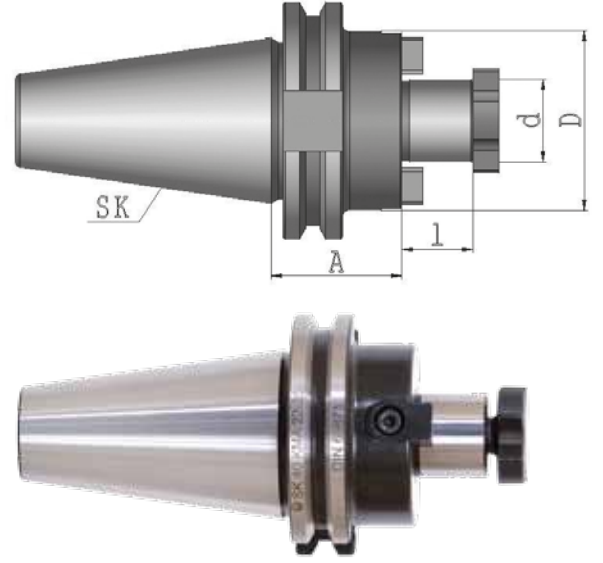

Teslim Şekli : Alın civatası kaması ve ile birlikte
Lieferumfang : Inkl. Mitnehmerring und Fräseranzugsschraube
Included : Drive and cruciform screw

Quernut - Aufsteckdorne DIN 6357 mit vergrößertem Bunddurchmesser
Shell mill holder DIN 6357 for cutters with driving slot

FORM AD/B

Sipariş No Bestell Nr. Order Nr.	SK	d	A	L1	D
016.31.16	SK 40	16	35	17	38
016.31.22	SK 40	22	35	19	48
016.31.27	SK 40	27	40	21	58
016.31.32	SK 40	32	50	24	78
016.31.40	SK 40	40	50	27	88
017.31.16	SK 50	16	35	17	38
017.31.22	SK 50	22	35	19	48
017.31.27	SK 50	27	40	21	58
017.31.32	SK 50	32	50	24	78
017.31.40	SK 50	40	50	27	88
017.31.60	SK 50	60	70	40	128

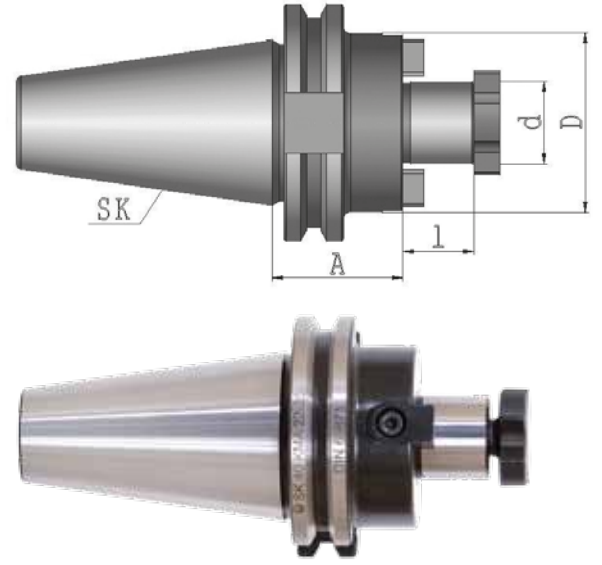

Teslim Şekli : Alın civatası kaması ve ile birlikte
Lieferumfang : Inkl. Mitnehmerring und Fräseranzugsschraube
Included : Drive and cruciform screw

Fräsdorne für Aufschraubfräfer
Milling Cutter Arbors for Screw-on type milling cutters

FORM AD/B

Sipariş No Bestell Nr. Order Nr.	SK	M	d1	d2	A	L	D
006.24.06-44	SK 40	6	6,5	10	44	25	13
006.24.06-69	SK 40	6	6,5	10	69	50	20
006.24.06-94	SK 40	6	6,5	10	94	75	23
006.24.08-44	SK 40	8	8,5	13	44	25	15
006.24.08-69	SK 40	8	8,5	13	69	50	23
006.24.08-94	SK 40	8	8,5	13	94	75	23
006.24.08-119	SK 40	8	8,5	13	119	100	25
006.24.10-44	SK 40	10	10,5	18	44	25	20
006.24.10-69	SK 40	10	10,5	18	69	50	23
006.24.10-94	SK 40	10	10,5	18	94	75	28
006.24.10-119	SK 40	10	10,5	18	119	100	32
006.24.10-169	SK 40	10	10,5	18	169	150	36,5
006.24.12-44	SK 40	12	12,5	21	44	25	24
006.24.12-69	SK 40	12	12,5	21	69	50	24
006.24.12-94	SK 40	12	12,5	21	94	75	31
006.24.12-119	SK 40	12	12,5	21	119	100	33
006.24.12-144	SK 40	12	12,5	21	144	125	36
006.24.12-169	SK 40	12	12,5	21	169	150	40
006.24.16-44	SK 40	16	17	29	44	25	29
006.24.16-69	SK 40	16	17	29	69	50	34
006.24.16-94	SK 40	16	17	29	94	75	34
006.24.16-119	SK 40	16	17	29	119	100	36
006.24.16-144	SK 40	16	17	29	144	125	40
006.24.16-169	SK 40	16	17	29	169	150	42,5

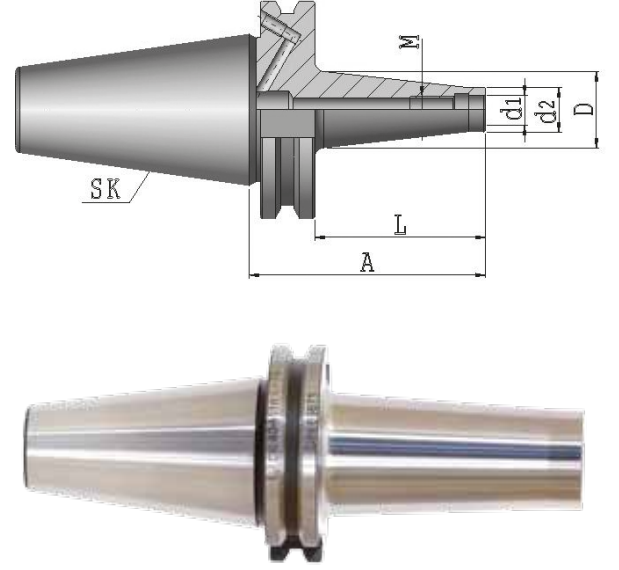

Fräsdorne für Aufschraubfräfer
Milling Cutter Arbors for Screw-on type milling cutters

FORM AD/B

Sipariş No Bestell Nr. Order Nr.	SK	M	d1	d2	A	L	D
007.24.08-69	SK 50	8	8,5	13	69	50	23
007.24.08-119	SK 50	8	8,5	13	119	100	25
007.24.08-169	SK 50	8	8,5	13	169	150	30
007.24.10-69	SK 50	10	10,5	18	69	50	23
007.24.10-119	SK 50	10	10,5	18	119	100	32
007.24.10-169	SK 50	10	10,5	18	169	150	36,5
007.24.12-69	SK 50	12	12,5	21	69	50	24
007.24.12-119	SK 50	12	12,5	21	119	100	33
007.24.12-169	SK 50	12	12,5	21	169	150	40
007.24.16-69	SK 50	16	17	29	69	50	34
007.24.16-119	SK 50	16	17	29	119	100	36
007.24.16-169	SK 50	16	17	29	169	150	42,5

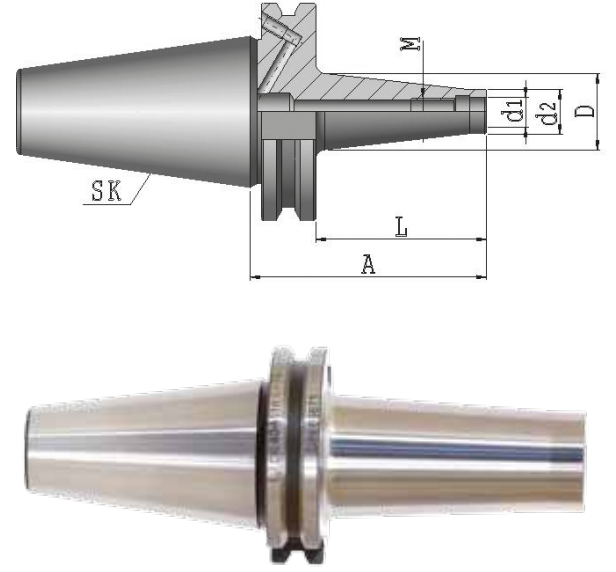

Bohrfutteraufnahme DIN 238
Drill chuck adaptor DIN 238

FORM A

Sipariş No Bestell Nr. Order Nr.	SK	d	A	L
005.32.12	SK 30	B12	38,5	18,5
005.32.16	SK 30	B16	40	24
006.32.12	SK 40	B12	25	18,5
006.32.16	SK 40	B16	25	24
006.32.18	SK 40	B18	35	32
007.32.16	SK 50	B16	25	24
007.32.18	SK 50	B18	25	32

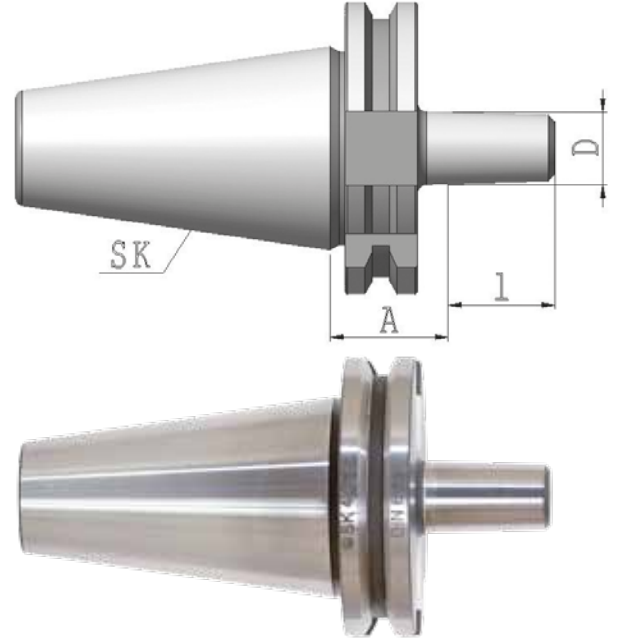

NC tipi mandren malafası komple sağ ve sol dönüşlü

DIN 69871 A

NC -Bohrfutter für Rechts und Linkslauf
NC - Drill chucks for left and right rotation

FORM A

Sipariş No Bestell Nr. Order Nr.	SK	d	Kapitesi Spannbereich Capacity	A	D
005.35.13	SK 30	1,0 - 13		97	51,5
006.35.13	SK 40	1,0 - 13		100	51,5
006.35.16	SK 40	3,0 - 16		116	57
007.35.13	SK 50	1,0 - 13		90	51,5
007.35.16	SK 50	3,0 - 16		120	58

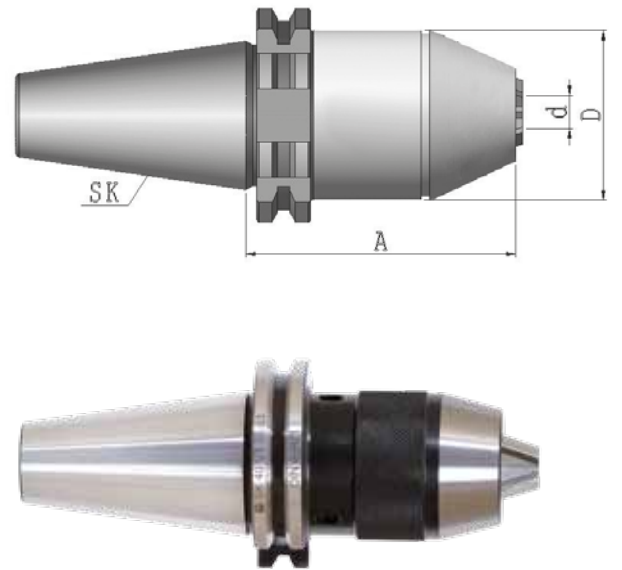

Teslim Şekli : Anahtar ile birlikte
Lieferumfang : Inkl. Spannschlüssel
Included : Wrench

Gewindeschneid - Schnellwechselfutter mit Längenausgleich auf Druck un Zug
Quick-change tapping chucks with length compensation

FORM A

Sipariş No Bestell Nr. Order Nr.	DK	Kapatesi Spannbereich Capacity	d	A	D	C	T
005.22.12	SK 30	M3-M14	19	61	38	7	7
005.22.24	SK 30	M5-M22	31	99	54	12	12
006.22.12	SK 40	M3-M14	19	61	38	7	7
006.22.24	SK 40	M5-M22	31	97	54	12	12
007.22.12	SK 50	M3-M14	19	67	38	7	7
007.22.24	SK 50	M5-M22	31	85	54	12	12

Teknik özelliği : Bilya kafesli.
Ausführung : Mit Kugelführungsbuchse
Version : With ball retainer

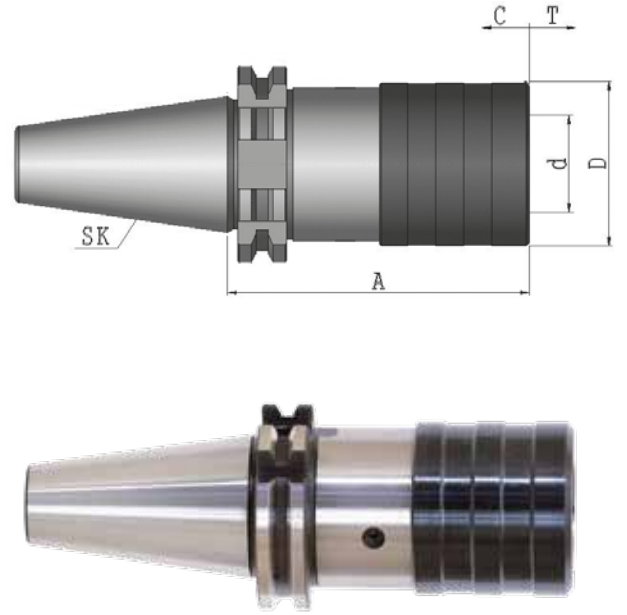

Bohrstangenrohlinge zur Anfertigung von Sonderwerkzeugen
Boring bar blanks for the production of special tools

FORM A

Sipariş No Bestell Nr. Order Nr.	DK	A	D
006.33.63	SK 40	250	63
007.33.97	SK 50	315	97

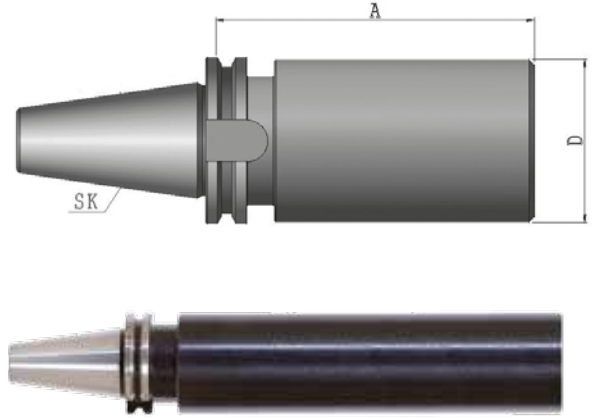

- Teknik özelliği : Konik ve Flanş kısmı sertleştirilmiş ve taşlanmış.
Bara kısmı işlenebilir yumuşaklıktadır.
- Ausführung : Steilkegel und Bund gehärtet und geschliffen,
Schaft weich zure weiteren Bearbeitung.
- Version : Cone and flange hardened and grinded.
Soft body for later processing.

Fener mili kontrol mastarı

DIN 69871 A

Kontrolldorne
Test arbors

FORM A

Sipariş No Bestell Nr. Order Nr.	DK	A	D
005.34.32	SK 30	200	32
006.34.40	SK 40	300	40
007.34.50	SK 50	300	50

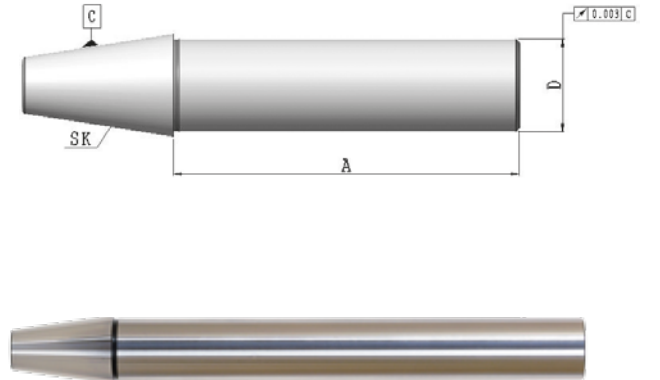

- Açıklama : Tezgahları devreye alırken ISO Normu R 230 sisteminde uygunluğunu kontrol etmek için
- Verwendung : Zur Abnahme von Werkzeugmaschinen gemäß ISO-Empfehlung R 230
- Application : For acceptance tests of machine tools in accordance with ISO-recommendation R 230
- Teslim Şekli : Sandığı ve Kontrol Sertifikasıyla birlikte
- Lieferung : Im Holzkasten mit Prüfprotokoll
- Verwendung : Zur Abnahme von Werkzeugmaschinen gemäß ISO-Empfehlung R 230
- Application : For acceptance tests of machine tools in accordance with ISO-recommendation R 230

JIS B 6339 (MAS 403 BT)

A-AD, AD/B

Takım Tutucular

Werkzeugaufnahmen

Toolholders



Werkzeugaufnahmen
Toolholders

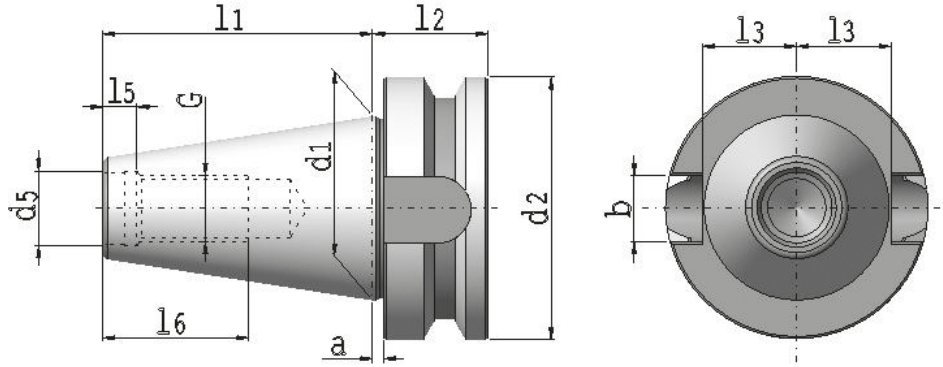

SK	d1	G	d5	d2	a	L1	L2	L3	L5	L6	E1	b	D9
30	31,75	M12	12,5	46	2	48,4	22	16,3	7,0	24	-	16,1	-
40	44,45	M16	17,0	63	2	65,4	27	22,5	8,2	32	27	16,1	4
50	69,85	M24	25,0	100	3	101,8	38	35,3	11,0	47	42	25,7	8

Merkezde ve Flanşta su delikleri vardır
Mit innerer Kühlmittelzufuhr
With internal coolant

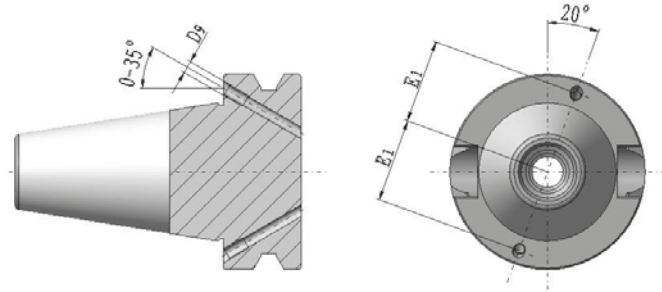

Malzeme : Alaşımlı semente çeliği çekme mukavemeti min. 950 N/mm²
Teknik özelliği : Sertlik HRC 58 ± 2 , sertlik derinliği 0,6 mm + 0,2 mm, karartılmış
Hassasiyeti : Konik açı toleransı kalitesi DIN 2080 normuna göre AT3
Konik Yüzey kalitesi max. 0,001 mm

Wekstoff : Legierter Einsatzstahl mit einer Zugfestigkeit im Kern von min. 950 N/mm²
Ausführung : Einsatzgeharter HRC 58 ± 2 , Harteriefe 0,6 mm + 0,2 mm brüniert
Genauigkeit : Kegelwinkel-Toleranzqualität AT 3 nach DIN 2080
Oberflächenrauigkeit des Kegels max. 0,001 mm

Material : Case hardened steel, tensile strength in the core min. 950 N/mm²
Execution : Case hardened HRC 58 ± 2 , Depth of case 0,6 mm + 0,2 mm, black - finish
Accuracy : Cone angle AT 3 according DIN 2080
Surface roughness of cone max. 0,001 mm

Spannfutter DIN 6391 für Spannzangen DIN 6388
Collet chucks DIN 6391 for Collets DIN 6388

FORM AD

Sipariş No Bestell Nr. Order Nr.	BT	Kapasite Spannbereich Capacity	A	D
010.01.16	BT 30	2 - 16	69	43
010.01.25	BT 30	3 - 25	80	60
011.01.16	BT 40	2 - 16	70	43
011.01.25	BT 40	2 - 25	70	60
011.01.32	BT 40	3 - 32	90	72
012.01.25	BT 50	2 - 25	85	60
012.01.32	BT 50	3 - 32	90	72

Teslim Şekli : Kapak ile birlikte
Lieferumfang : Inkl. Spannmutter
Included : Clamping nut

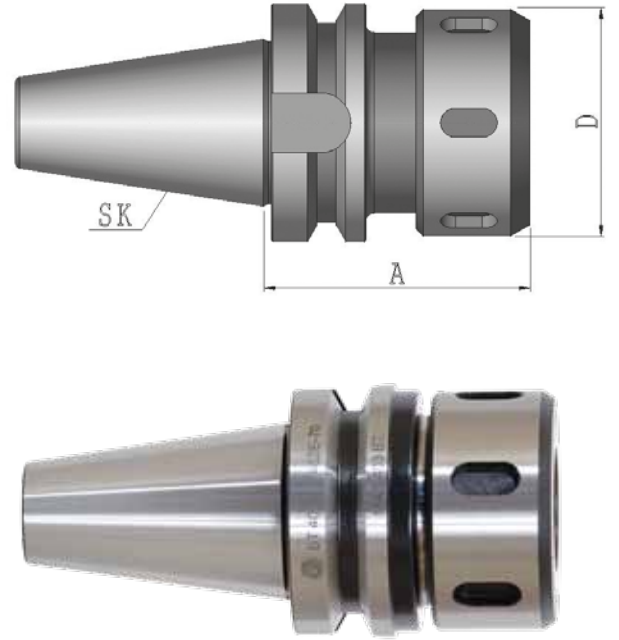

Spannfutter DIN 6391 für Spannzangen DIN 6388
Collet chucks DIN 6391 for Collets DIN 6388

FORM AD/B

Sipariş No Bestell Nr. Order Nr.	BT	Kapasite Spannbereich Capacity	A	D
111.01.16	BT 40	2 - 16	70	43
111.01.25	BT 40	2 - 25	70	60
111.01.32	BT 40	3 - 32	90	72

Teslim Şekli : Kapak ile birlikte
Lieferumfang : Inkl. Spannmutter
Included : Clamping nut

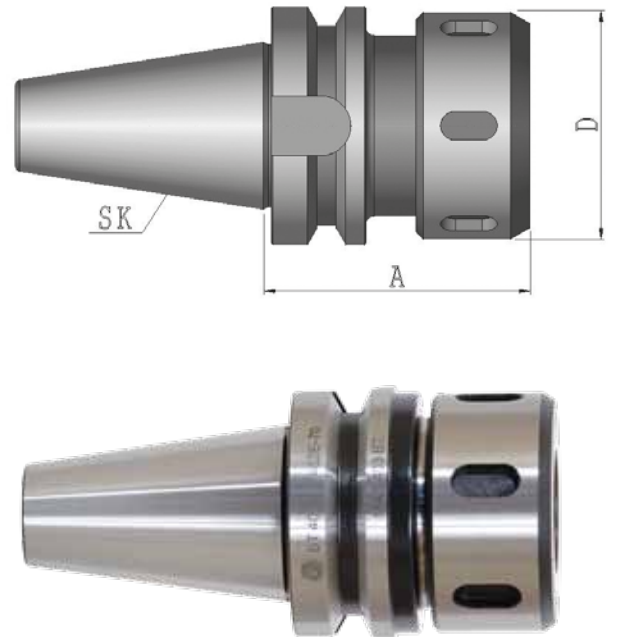

Spannfutter für Spannzangen DIN 6499 ER
Collet chucks for Collets DIN 6499 ER

FORM AD

Sipariş No Bestell Nr. Order Nr.	BT	Kapasite Spannbereich Capacity	A	D
010.02.10	BT 30	ER 16 1 - 10	63	32
010.02.10-100	BT 30	ER 16 1 - 10	100	32
010.02.16	BT 30	ER 25 2 - 16	60	42
010.02.16-100	BT 30	ER 25 2 - 16	100	42
010.02.20	BT 30	ER 32 2 - 20	70	50
010.02.20-100	BT 30	ER 32 2 - 20	100	50
010.02.26	BT 30	ER 40 3 - 26	80	63
011.02.10	BT 40	ER 16 1 - 10	63	32
011.02.10-100	BT 40	ER 16 1 - 10	100	32
011.02.10-160	BT 40	ER 16 1 - 10	160	32
011.02.16	BT 40	ER 25 2 - 16	60	42
011.02.16-100	BT 40	ER 25 2 - 16	100	42
011.02.16-160	BT 40	ER 25 2 - 16	160	42
011.02.20	BT 40	ER 32 2 - 20	70	50
011.02.20-100	BT 40	ER 32 2 - 20	100	50
011.02.20-160	BT 40	ER 32 2 - 20	160	50
011.02.26	BT 40	ER 40 3 - 26	80	63
011.02.26-100	BT 40	ER 40 3 - 26	100	63
011.02.26-160	BT 40	ER 40 3 - 26	160	63
012.02.10	BT 50	ER 16 1 - 10	70	32
012.02.10-100	BT 50	ER 16 1 - 10	100	32
012.02.10-160	BT 50	ER 16 1 - 10	160	32
012.02.16	BT 50	ER 25 2 - 16	60	42
012.02.16-100	BT 50	ER 25 2 - 16	100	42
012.02.16-160	BT 50	ER 25 2 - 16	160	42
012.02.20	BT 50	ER 32 2 - 20	70	50
012.02.20-100	BT 50	ER 32 2 - 20	100	50
012.02.20-160	BT 50	ER 32 2 - 20	160	50
012.02.26	BT 50	ER 40 3 - 26	80	63
012.02.26-100	BT 50	ER 40 3 - 26	100	63
012.02.26-160	BT 50	ER 40 3 - 26	160	63

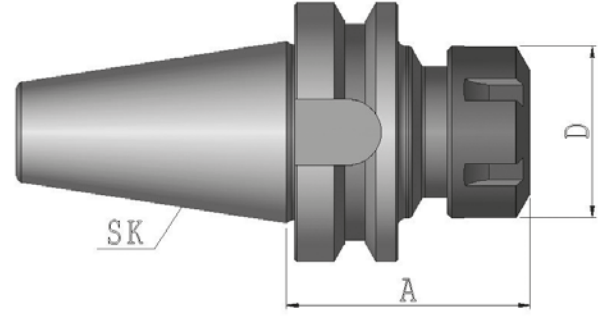

Teslim Şekli : Kapak ile birlikte
Lieferumfang : Inkl. Spannmutter
Included : Clamping nut

Spannfutter für Spannzangen DIN 6499 ER
Collet chucks for Collets DIN 6499 ER

FORM AD/B

Sipariş No Bestell Nr. Order Nr.	BT	Kapasite Spannbereich Capacity	A	D
111.02.10	BT 40	ER 16 1 - 10	63	32
111.02.10-100	BT 40	ER 16 1 - 10	100	32
111.02.10-160	BT 40	ER 16 1 - 10	160	32
111.02.16	BT 40	ER 25 2 - 16	60	42
111.02.16-100	BT 40	ER 25 2 - 16	100	42
111.02.16-160	BT 40	ER 25 2 - 16	160	42
111.02.20	BT 40	ER 32 2 - 20	70	50
111.02.20-100	BT 40	ER 32 2 - 20	100	50
111.02.20-160	BT 40	ER 32 2 - 20	160	50
111.02.26	BT 40	ER 40 3 - 26	80	63
111.02.26-100	BT 40	ER 40 3 - 26	100	63
111.02.26-160	BT 40	ER 40 3 - 26	160	63
112.02.10	BT 50	ER 16 1 - 10	70	32
112.02.10-100	BT 50	ER 16 1 - 10	100	32
112.02.10-160	BT 50	ER 16 1 - 10	160	32
112.02.16	BT 50	ER 25 2 - 16	70	42
112.02.16-100	BT 50	ER 25 2 - 16	100	42
112.02.16-160	BT 50	ER 25 2 - 16	160	42
112.02.20	BT 50	ER 32 2 - 20	70	50
112.02.20-100	BT 50	ER 32 2 - 20	100	50
112.02.20-160	BT 50	ER 32 2 - 20	160	50
112.02.26	BT 50	ER 40 3 - 26	80	63
112.02.26-100	BT 50	ER 40 3 - 26	100	63
112.02.26-160	BT 50	ER 40 3 - 26	160	63

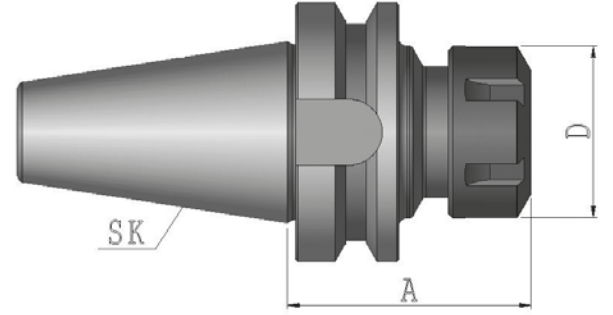

Teslim Şekli : Kapak ile birlikte
Lieferumfang : Inkl. Spannmutter
Included : Clamping nut

Präzisionskraftutter
Precision Milling Chuck

FORM AD

Sipariş No Bestell Nr. Order Nr.	BT	Kapatesi Spannbereich Capacity	d	A	D
011.03.25	BT 40	CKS 25 6 - 25	25	90	58
011.03.32	BT 40	CKS 32 6 - 32	32	95	68
012.03.25	BT 50	CKS 25 6 - 25	25	95	58
012.03.32	BT 50	CKS 32 6 - 32	32	105	68

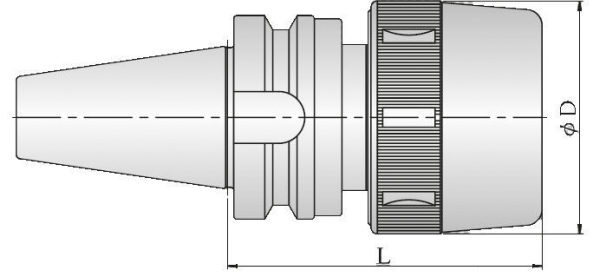

Bilyalı pens tutucu seti plastik kutuda

JIS B 6339 (MAS 403 BT)AD

Präzisionskraftspannfutter satz im Koffer
Precision Milling Chuck set in box

FORM AD

Sipariş No Bestell Nr. Order Nr.	BT	Kapatesi Spannbereich Capacity	Pens Adeti Spannzangen Stk. Collet Pcs.
011.53.25	BT 40	CKS 25 6 - 25	6-8-10-12-16-20
011.53.32	BT 40	CKS 32 6 - 32	6-8-10-12-16-20-25
012.53.25	BT 50	CKS 25 6 - 25	6-8-10-12-16-20
012.53.32	BT 50	CKS 32 6 - 32	6-8-10-12-16-20-25



Teslim Şekli : Takım, pensleri ve anahtarıyla birlikte
Lieferumfang : Spannutter, inkl. Spannzangen mit Schlüssel
Included : Collet chuck with collets and wrench

Fräseraufnahmen DIN 6359 für Zylinderschäfte DIN 1835-B
End mill holder DIN 6359 for weldon type end mills BIN 1835-B

FORM AD

Sipariş No Bestell Nr. Order Nr.	BT	d	A	D
010.10.06	BT 30	6	50	25
010.10.06-100	BT 30	8	50	28
010.10.08	BT 30	10	50	35
010.10.08-100	BT 30	12	50	42
010.10.10	BT 30	14	50	44
010.10.10-100	BT 30	16	63	48
010.10.12	BT 30	18	63	50
010.10.12-100	BT 30	20	63	52
011.10.06	BT 40	6	50	25
011.10.06-100	BT 40	6	100	25
011.10.08	BT 40	8	50	28
011.10.08-100	BT 40	8	100	28
011.10.10	BT 40	10	63	35
011.10.10-100	BT 40	10	100	35
011.10.12	BT 40	12	63	42
011.10.12-100	BT 40	12	100	42
011.10.14	BT 40	14	63	44
011.10.14-100	BT 40	14	100	44
011.10.16	BT 40	16	35	45
011.10.16-35	BT 40	16	63	48
011.10.16-100	BT 40	16	100	48
011.10.18	BT 40	18	63	50
011.10.18-100	BT 40	18	100	50
011.10.20	BT 40	20	35	45
011.10.20-35	BT 40	20	63	52
011.10.20-100	BT 40	20	100	52
011.10.25	BT 40	25	35	45
011.10.25-35	BT 40	25	90	65
011.10.32	BT 40	32	65	62
011.10.32-65	BT 40	32	100	72
011.10.40	BT 40	40	120	80

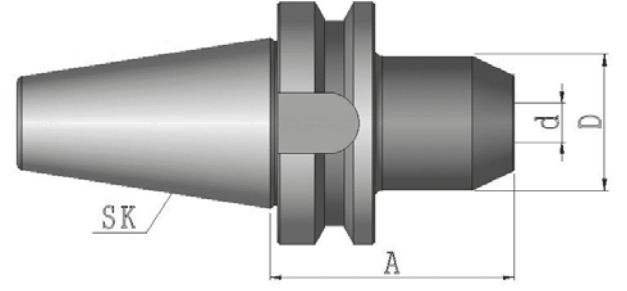

Teslim Şekli : Sıkma civatası ile birlikte
Lieferumfang : Inkl. Spannschraube
Included : Clamping screw

Hinweis : Bohrungstoleranz H4
Application : Boring tolerance H4
Açıklama : İç çap toleransı H4

Fräseraufnahmen DIN 6359 für Zylinderschäfte DIN 1835-B
End mill holder DIN 6359 for weldon type end mills BIN 1835-B

FORM AD

Sipariş No Bestell Nr. Order Nr.	BT	d	A	D
012.10.06	BT 50	6	63	25
012.10.08	BT 50	8	63	28
012.10.10	BT 50	10	63	35
012.10.12	BT 50	12	80	42
012.10.14	BT 50	14	80	44
012.10.16	BT 50	16	80	48
012.10.18	BT 50	18	80	50
012.10.20	BT 50	20	80	52
012.10.25	BT 50	25	100	65
012.10.32	BT 50	32	105	72
012.10.40	BT 50	40	110	80

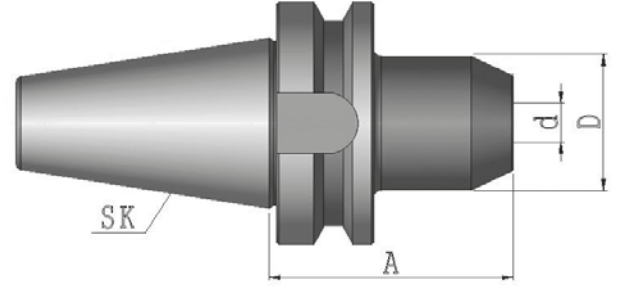

Teslim Şekli : Sıkma civatası ile birlikte
Lieferumfang : Inkl. Spannschraube
Included : Clamping screw

Hinweis : Bohrungstoleranz H4
Application : Boring tolerance H4
Açıklama : İç çap toleransı H4

Fräseraufnahmen DIN 6359 für Zylinderschäfte DIN 1835-B
End mill holder DIN 6359 for weldon type end mills BIN 1835-B

FORM AD/B

Sipariş No Bestell Nr. Order Nr.	BT	d	A	D
111.10.06	BT 40	6	50	25
111.10.06-100	BT 40	6	100	25
111.10.06-160	BT 40	6	160	25
111.10.08	BT 40	8	50	28
111.10.08-100	BT 40	8	100	28
111.10.08-160	BT 40	8	160	28
111.10.10	BT 40	10	63	35
111.10.10-100	BT 40	10	100	35
111.10.10-160	BT 40	10	160	35
111.10.12	BT 40	12	63	42
111.10.12-100	BT 40	12	100	42
111.10.12-160	BT 40	12	160	42
111.10.14	BT 40	14	63	44
111.10.14-100	BT 40	14	100	44
111.10.14-160	BT 40	14	160	44
111.10.16	BT 40	16	63	48
111.10.16-100	BT 40	16	100	48
111.10.16-160	BT 40	16	160	48
111.10.18	BT 40	18	63	50
111.10.18-100	BT 40	18	100	50
111.10.18-160	BT 40	18	160	50
111.10.20	BT 40	20	63	52
111.10.20-100	BT 40	20	100	52
111.10.20-160	BT 40	20	160	52
111.10.25	BT 40	25	90	65
111.10.25-160	BT 40	25	160	65
111.10.32	BT 40	32	100	72
111.10.32-160	BT 40	32	160	72
111.10.40	BT 40	40	120	80

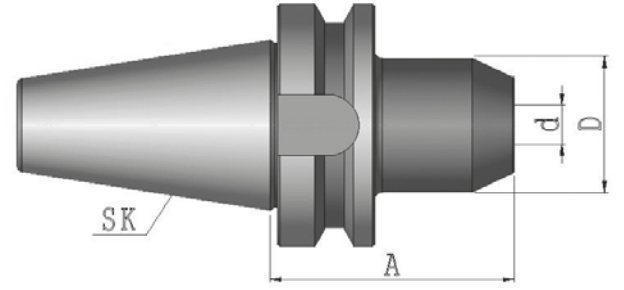

Teslim Şekli : Sıkma civatası ile birlikte
Lieferumfang : Inkl. Spannschraube
Included : Clamping screw

Hinweis : Bohrungstoleranz H4
Application : Boring tolerance H4
Açıklama : İç çap toleransı H4

Fräsaufnahmen DIN 6359 für Zylinderschäfte DIN 1835-B
End mill holder DIN 6359 for weldon type end mills BIN 1835-B

FORM AD/B

Sipariş No Bestell Nr. Order Nr.	BT	d	A	D
112.10.06	BT 50	6	63	25
112.10.08	BT 50	8	63	28
112.10.10	BT50	10	63	35
112.10.12	BT 50	12	80	42
112.10.14	BT 50	14	80	44
112.10.16	BT 50	16	80	48
112.10.18	BT 50	18	80	50
112.10.20	BT 50	20	80	52
112.10.25	BT 50	25	100	65
112.10.32	BT 50	32	105	72
112.10.40	BT 50	40	110	80

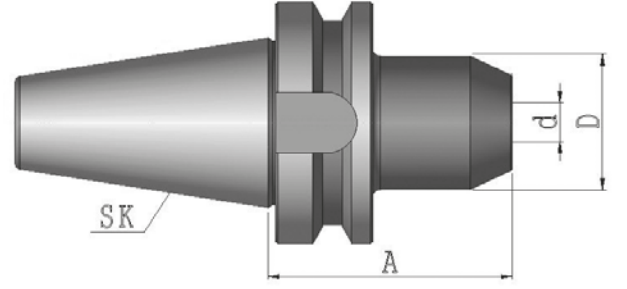

Teslim Şekli : Sıkma civatası ile birlikte
Lieferumfang : Inkl. Spannschraube
Included : Clamping screw

Hinweis : Bohrungstoleranz H4
Application : Boring tolerance H4
Açıklama : İç çap toleransı H4

Zwischenhülsen für MK mit Austreibblappen DIN 6383
Morse taper adaptor DIN 6383

FORM AD

Sipariş No Bestell Nr. Order Nr.	BT	MK	A	D
010.20.01	BT 30	1	50	25
010.20.02	BT 30	2	50	32
010.20.03	BT 30	3	70	40
011.20.01	BT 40	1	50	25
011.20.02	BT 40	2	50	32
011.20.03	BT 40	3	70	40
011.20.04	BT 40	4	95	48
012.20.01	BT 50	1	50	25
012.20.02	BT 50	2	50	32
012.20.03	BT 50	3	70	40
012.20.04	BT 50	4	95	48
012.20.05	BT 50	5	105	63

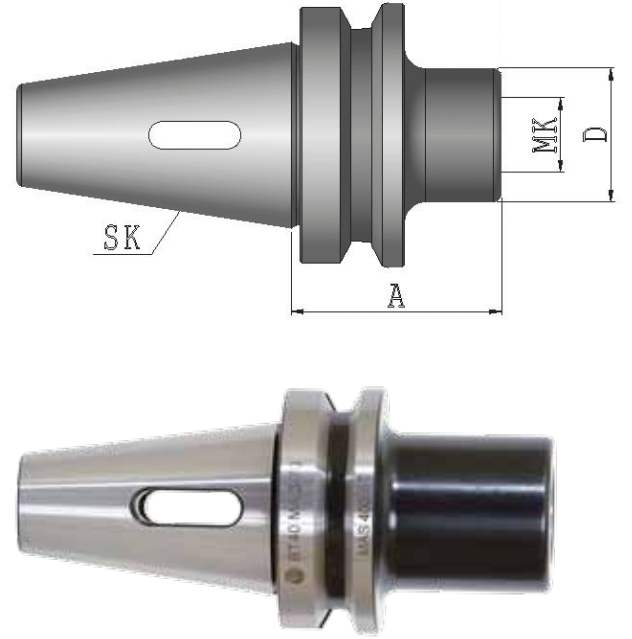

Zwischenhülsen für MK mit Anzugsgewinde DIN 6364

Morse taper adaptor for tools with morse taper shank and drawbar thread DIN 6364

FORM A

Sipariş No Bestell Nr. Order Nr.	BT	MK	A	D
011.21.01	BT 40	1	50	25
011.21.02	BT 40	2	50	32
011.21.03	BT 40	3	70	40
011.21.04	BT 40	4	95	48
012.21.01	BT 50	1	45	25
012.21.02	BT 50	2	60	32
012.21.03	BT 50	3	65	40
012.21.04	BT 50	4	70	48
012.21.05	BT 50	5	100	63

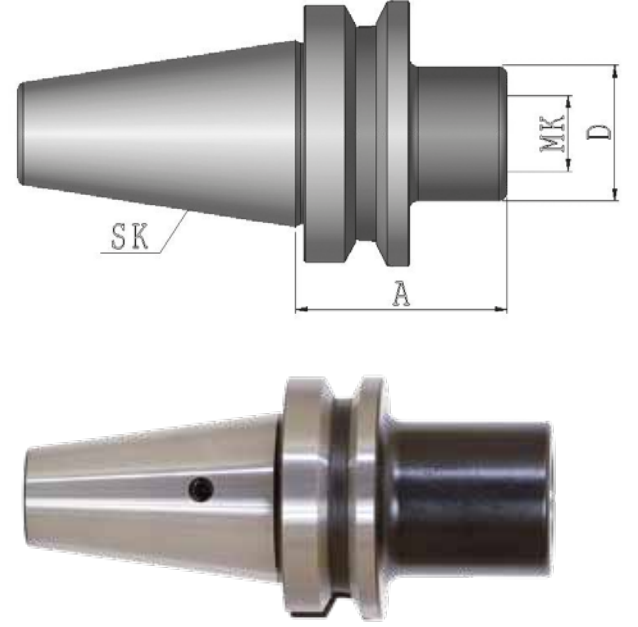

* Taşıyıcı yuvalı DIN 2201

* Mit Mitnehmerausfrassung nach DIN 2201

* With driving facilities to DIN 2201

Montaj civatası ile beraber

Lieferung erfolgt mit einegebauter Schraube

Delivery with build-in screw

Zwischenhülsen / Reduzierhülsen
Reduction Sleeves

FORM A

Sipariş No Bestell Nr. Order Nr.	BT	SK ₁	A	D
011.23.40	BT 40	SK-40	100	63
012.23.50	BT 50	SK-40	70	70
012.23.50	BT 50	SK-50	120	97

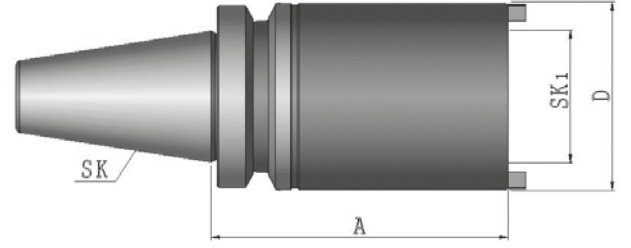

DIN 2080 Konik çektirme civatası ile birlikte
Lieferung erfolgt mit einegebauter Schraube für
Werkzeuge mit gekürztem Steilkegel
Schraube für DIN 2080 Werkzeuge beiliegend
Including a built-in screw for shortened taper tools,
Additional one screw for DIN 2080 tools



Kombi - Aufsteckfräserdorne DIN 6358
Combi shell mill holder DIN 6358

FORM AD

Sipariş No Bestell Nr. Order Nr.	BT	d	A	L1	D
010.30.16	BT 30	16	45	17	32
010.30.22	BT 30	22	47	19	40
010.30.27	BT 30	27	49	21	48
011.30.16	BT 40	16	55	17	32
011.30.16-100	BT 40	16	100	17	32
011.30.22	BT 40	22	55	19	40
011.30.22-100	BT 40	22	100	19	40
011.30.27	BT 40	27	55	21	48
011.30.27-100	BT 40	27	100	21	48
011.30.32	BT 40	32	60	24	58
011.30.32-100	BT 40	32	100	24	58
011.30.40	BT 40	40	60	27	70
011.30.40-100	BT 40	40	100	27	70
012.30.16	BT 50	16	70	17	32
012.30.16-100	BT 50	16	100	17	32
012.30.22	BT 50	22	70	19	40
012.30.22-100	BT 50	22	100	19	40
012.30.27	BT 50	27	70	21	48
012.30.27-100	BT 50	27	100	21	48
012.30.32	BT 50	32	70	24	58
012.30.32-100	BT 50	32	100	24	58
012.30.40	BT 50	40	70	27	70
012.30.40-100	BT 50	40	100	27	70

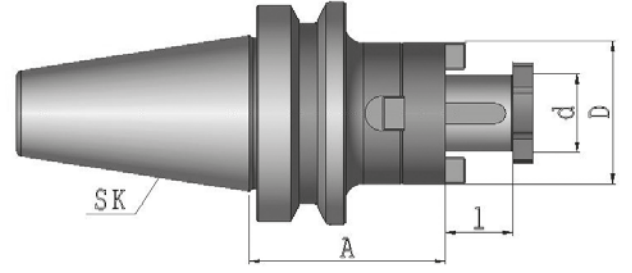

Teslim Şekli : Alın civatası, kaması ve tırnaklı pulu ile birlikte
Lieferumfang : Inklusive Paßfeder, Mitnehmerring und Fräseranzugsschraube
Included : Milling cutter retention, screw, drive key with threaded hole
for push-out screw, combination drive ring

Kombi - Aufsteckfräserdorne DIN 6358
Combi shell mill holder DIN 6358

FORM AD/B

Sipariş No Bestell Nr. Order Nr.	BT	d	A	L1	D
111.30.16	BT 40	16	55	17	32
111.30.16-100	BT 40	16	100	17	32
111.30.22	BT 40	22	55	19	40
111.30.22-100	BT 40	22	100	19	40
111.30.27	BT 40	27	55	21	48
111.30.27-100	BT 40	27	100	21	48
111.30.32	BT 40	32	60	24	58
111.30.32-100	BT 40	32	100	24	58
111.30.40	BT 40	40	60	27	70
111.30.40-100	BT 40	40	100	27	70
112.30.16	BT 50	16	70	17	32
112.30.16-100	BT 50	16	100	17	32
112.30.22	BT 50	22	70	19	40
112.30.22-100	BT 50	22	100	19	40
112.30.27	BT 50	27	70	21	48
112.30.27-100	BT 50	27	100	21	48
112.30.32	BT 50	32	70	24	58
112.30.32-100	BT 50	32	100	24	58
112.30.40	BT 50	40	70	27	70
112.30.40-100	BT 50	40	100	27	70

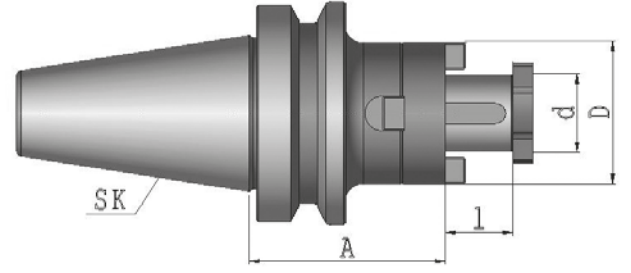

Teslim Şekli : Alın civatası, kaması ve tırnaklı pulu ile birlikte
Lieferumfang : Inklusive Paßfeder, Mitnehmerring und Fräseranzugsschraube
Included : Milling cutter retention, screw, drive key with threaded hole
for push-out screw, combination drive ring

Quernut - Aufsteckdorne DIN 6357 mit vergrößertem Bunddurchmesser
Shell mill holder DIN 6357 for cutters with driving slot

FORM A

Sipariş No Bestell Nr. Order Nr.	BT	d	A	L1	D
010.31.16	BT 30	16	40	17	38
010.31.22	BT 30	22	40	19	48
010.31.27	BT 30	27	40	21	58
010.31.32	BT 30	32	50	24	78
011.31.16	BT 40	16	40	17	38
011.31.16-100	BT 40	16	100	17	38
011.31.16-160	BT 40	16	160	17	38
011.31.22	BT 40	22	40	19	48
011.31.22-100	BT 40	22	100	19	48
011.31.22-160	BT 40	22	160	19	48
011.31.27	BT 40	27	40	21	58
011.31.27-100	BT 40	27	100	21	58
011.31.27-160	BT 40	27	160	21	58
011.31.32	BT 40	32	50	24	78
011.31.32-100	BT 40	32	100	24	78
011.31.32-160	BT 40	32	160	24	78
011.31.40	BT 40	40	50	27	88
011.31.40-100	BT 40	40	100	27	88
011.31.40-160	BT 40	40	160	27	88
012.31.16	BT 50	16	55	17	38
012.31.16-100	BT 50	16	100	17	38
012.31.16-160	BT 50	16	160	17	38
012.31.22	BT 50	22	55	19	48
012.31.22-100	BT 50	22	100	19	48
012.31.22-160	BT 50	22	160	19	48
012.31.27	BT 50	27	55	21	58
012.31.27-100	BT 50	27	100	21	58
012.31.27-160	BT 50	27	160	21	58
012.31.32	BT 50	32	55	24	78
012.31.32-100	BT 50	32	100	24	78
012.31.32-160	BT 50	32	160	24	78
012.31.40	BT 50	40	55	27	88
012.31.40-100	BT 50	40	100	27	88
012.31.40-160	BT 50	40	160	27	88
012.31.60	BT 50	60	80	40	128

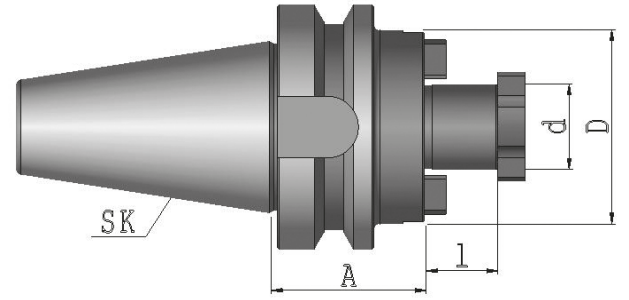

Teslim Şekli : Alın civatası ve kaması ile birlikte
Lieferumfang : Inkl. Mitnehmerring und Fräseranzugsschraube
Included : Drive and cruciform screw

Quernut - Aufsteckdorne DIN 6357 mit vergrößertem Bunddurchmesser
Shell mill holder DIN 6357 for cutters with driving slot

FORM AD/B

Sipariş No Bestell Nr. Order Nr.	BT	d	A	L1	D
111.31.16	BT 40	16	40	17	38
111.31.22	BT 40	22	40	19	48
111.31.22-100	BT 40	22	100	19	48
111.31.27	BT 40	27	40	21	58
111.31.27-100	BT 40	27	100	21	58
111.31.32	BT 40	32	50	24	78
111.31.32-100	BT 40	32	100	24	78
111.31.40	BT 40	40	50	27	88
111.31.40-100	BT 40	40	100	27	88
112.31.22	BT 50	22	55	19	48
112.31.22-100	BT 50	22	100	19	48
112.31.27	BT 50	27	55	21	58
112.31.27-100	BT 50	27	100	21	58
112.31.32	BT 50	32	55	24	78
112.31.32-100	BT 50	32	100	24	78
112.31.40	BT 50	40	55	27	88
112.31.40-100	BT 50	40	100	27	88
112.31.60	BT 50	60	80	40	128

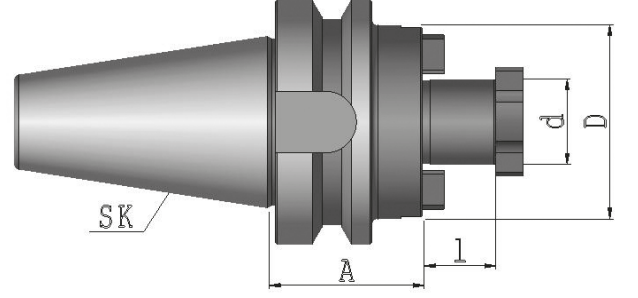

Teslim Şekli : Alın civatası ve kaması ile birlikte
Lieferumfang : Inkl. Mitnehmerring und Fräseranzugsschraube
Included : Drive and cruciform screw

Fräsdorne für Aufschraubfräser
Milling Cutter Arbors for Screw-on type milling cutters

FORM AD/B

Sipariş No Bestell Nr. Order Nr.	BT	M	d1	d2	A	L	D
011.24.06-52	BT 40	6	6,5	10	52	25	13
011.24.06-77	BT 40	6	6,5	10	77	50	20
011.24.06-102	BT 40	6	6,5	10	102	75	23
011.24.08-52	BT 40	8	8,5	13	52	25	15
011.24.08-77	BT 40	8	8,5	13	77	50	23
011.24.08-102	BT 40	8	8,5	13	102	75	23
011.24.08-127	BT 40	8	8,5	13	127	100	25
011.24.10-52	BT 40	10	10,5	18	52	25	20
011.24.10-77	BT 40	10	10,5	18	77	50	23
011.24.10-102	BT 40	10	10,5	18	102	75	28
011.24.10-127	BT 40	10	10,5	18	127	100	32
011.24.10-177	BT 40	10	10,5	18	177	150	36,5
011.24.12-52	BT 40	12	12,5	21	52	25	24
011.24.12-77	BT 40	12	12,5	21	77	50	24
011.24.12-102	BT 40	12	12,5	21	102	75	31
011.24.12-127	BT 40	12	12,5	21	127	100	33
011.24.12-152	BT 40	12	12,5	21	152	125	36
011.24.12-177	BT 40	12	12,5	21	177	150	40
011.24.16-52	BT 40	16	17	29	52	25	29
011.24.16-77	BT 40	16	17	29	77	50	29
011.24.16-102	BT 40	16	17	29	102	75	34
011.24.16-127	BT 40	16	17	29	127	100	36
011.24.16-152	BT 40	16	17	29	152	125	40
011.24.16-177	BT 40	16	17	29	177	150	42,5

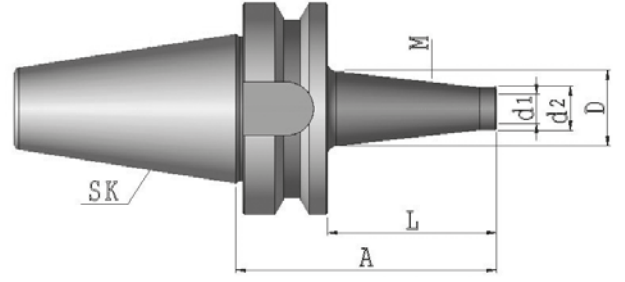

Fräsdorne für Aufschraubfräser
Milling Cutter Arbors for Screw-on type milling cutters

FORM AD

Sipariş No Bestell Nr. Order Nr.	BT	M	d1	d2	A	L	D
012.24.08-88	BT 50	8	8,5	13	88	50	23
012.24.08-138	BT 50	8	8,5	13	138	100	25
012.24.08-188	BT 50	8	8,5	13	188	150	30
012.24.10-88	BT 50	10	10,5	18	88	50	23
012.24.10-138	BT 50	10	10,5	18	138	100	32
012.24.10-188	BT 50	10	10,5	18	188	150	36,5
012.24.12-88	BT 50	12	12,5	21	88	50	24
012.24.12-138	BT 50	12	12,5	21	138	100	36
012.24.12-188	BT 50	12	12,5	21	188	150	40
012.24.16-88	BT 50	16	17	29	88	50	34
012.24.16-138	BT 50	16	17	29	138	100	36
012.24.16-188	BT 50	16	17	29	188	150	42,5

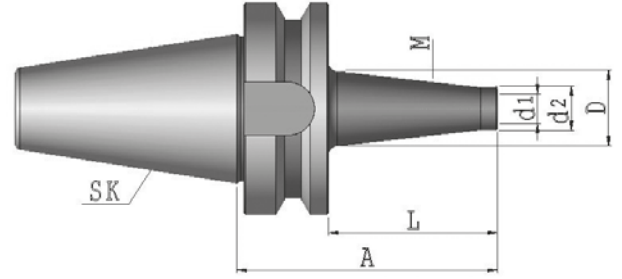

Bohrfutteraufnahme DIN 238
Drill chuck adaptor DIN 238

FORM A

Sipariş No Bestell Nr. Order Nr.	BT	d	A	L
010.32.12	BT 30	B12	25	18,5
010.32.16	BT 30	B16	25	24
011.32.12	BT 40	B12	32	18,5
011.32.16	BT 40	B16	35	24
011.32.18	BT 40	B18	32	32
012.32.16	BT 50	B16	43	24
012.32.18	BT 50	B18	43	32

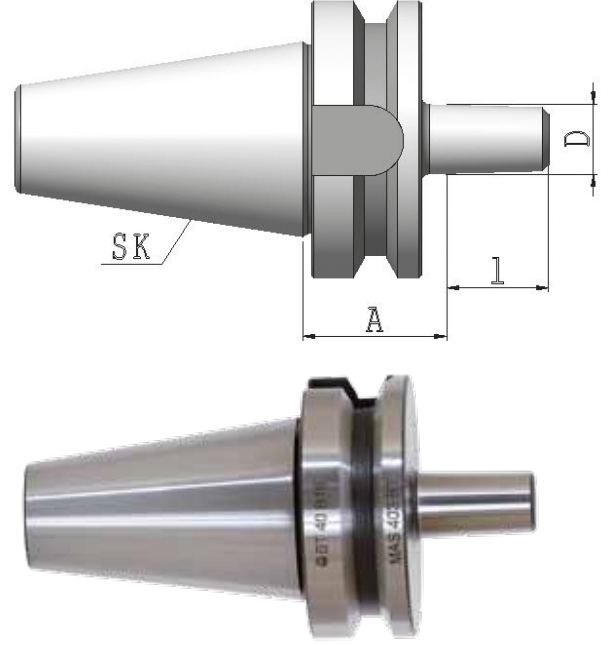

NC tipi mandren malafası komple sağ ve sol dönüşlü

JIS B 6339 (MAS 403 BT)A

NC -Bohrfutter für Rechts und Linkslauf
NC - Drill chucks for left and right rotation

FORM A

Sipariş No Bestell Nr. Order Nr.	BT	Kapatesi Spannbereich Capacity d	A	D
010.35.13	BT 30	1-13	97	51,5
011.35.13	BT 40	1-13	100	51,5
011.35.16	BT 40	3-16	116	58
012.35.13	BT 50	1-13	90	51,5
012.35.16	BT 50	3-16	120	58

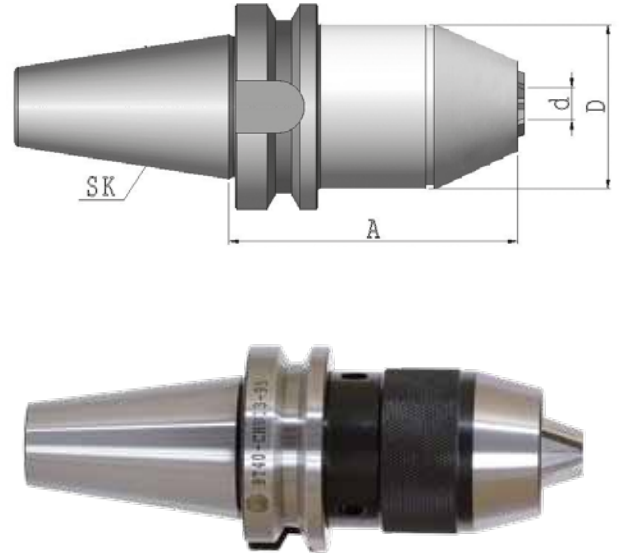

Gewindeschneid - Schnellwechselfutter mit Längenausgleich auf Druck un Zug
Quick-change tapping chucks with length compensation

FORM A

Sipariş No Bestell Nr. Order Nr.	BT	Kapatesi Spannbereich Capacity	d	A	D	C	T
010.22.12	BT 30	M3-M14	19	64	38	7	7
010.22.24	BT 30	M5-M22	31	95	54	12	12
011.22.12	BT40	M3-M14	19	67	38	7	7
011.22.24	BT40	M5-M22	31	93	54	12	12
012.22.12	BT50	M3-M14	19	82	38	7	7
012.22.24	BT50	M5-M22	31	100	54	12	12

Teknik özelliği : Bilya kafesli.
Ausführung : Mit Kugelführungsbuchse
Version : With ball retainer

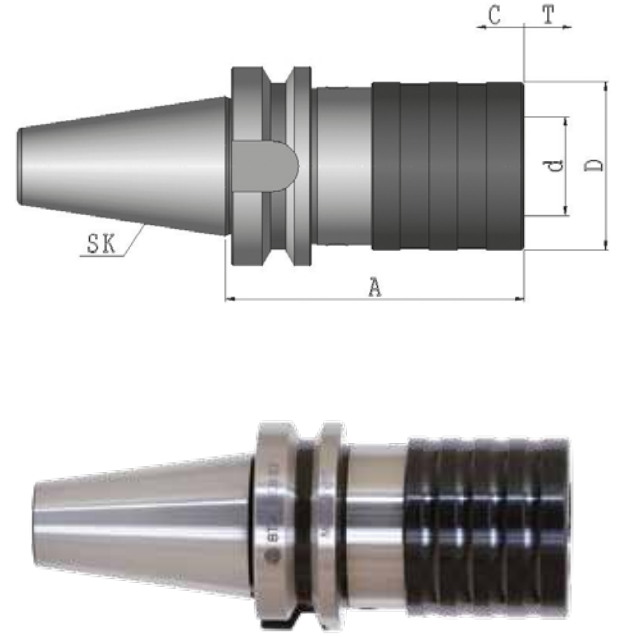

Bohrstangenrohlinge zur Anfertigung von Sonderwerkzeugen
Boring bar blanks for the production of special tools

FORM A

Sipariş No Bestell Nr. Order Nr.	BT	A	D
011.33.63	BT 40	250	63
012.33.97	BT 50	315	97

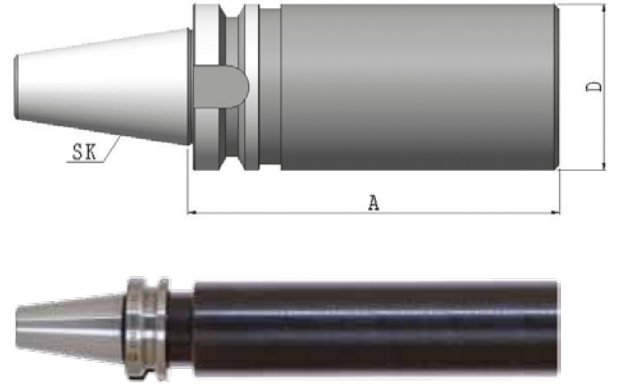

- Teknik özelliği : Konik ve Flanş kısmı sertleştirilmiş ve taşlanmıştır.
Bara kısmı işlenebilir yumuşaklıktadır.
- Ausführung : Steilkegel und Bund gehärtet und geschliffen,
Schaft weich zure weiteren Bearbeitung.
- Version : Cone and flange hardened and grinded.
Soft body for later processing.

Fener mili kontrol mastarı

JIS B 6339 (MAS 403 BT) A

Kontrolldorne
Test arbors

FORM A

Sipariş No Bestell Nr. Order Nr.	BT	A	D
010.34.32	BT 30	200	32
011.34.40	BT 40	300	40
012.34.50	BT 50	300	50

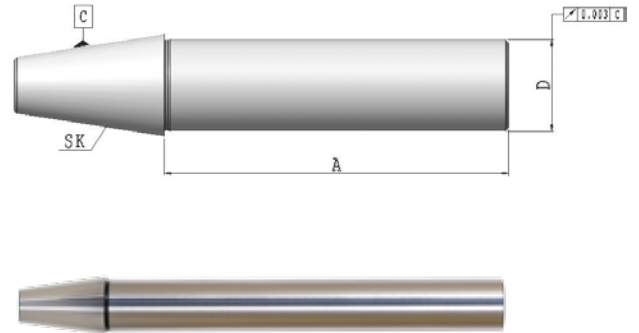

- Açıklama : Tezgahları devreye alırken ISO Normu R 230 sisteminde uygunluğunu kontrol etmek için
- Verwendung : Zur Abnahme von Werkzeugmaschinen gemäß ISO-Empfehlung R 230
- Application : For acceptance tests of machine tools in accordance with ISO-recommendation R 230
- Teslim Şekli : Sandığı ve Kontrol Sertifikasıyla birlikte
- Lieferung : Im Holzkasten mit Prüfprotokoll
- Verwendung : Zur Abnahme von Werkzeugmaschinen gemäß ISO-Empfehlung R 230
- Application : For acceptance tests of machine tools in accordance with ISO-recommendation R 230

Yedekler
Zubehör
Accessories



Spannfutter mit Zylinderschaft durchbohrt
Collet chuck with cylindrical shank bored through

Sipariş No Bestell Nr. Order Nr.	d	Kapasite Spannbereich Capacity	L	L1	D
030.02.13.16-100	16	ER20 1-13	100	44	34
030.02.13.16-150	16	ER20 1-13	150	44	34
030.02.13.20-100	20	ER20 1-13	100	44	34
030.02.13.20-150	20	ER20 1-13	150	44	34
030.02.10.16-150	16	ER16 1-10	150	30	32
030.02.10.16	16	ER16 1-10	70	30	32
030.02.10.20	20	R16 1-10	70	30	32
030.02.10.20-150	20	ER16 1-10	150	30	32
030.02.10.25	25	ER16 1-10	70	30	32
030.02.10.25-150	25	ER10 1-10	150	30	32
030.02.16.20-150	20	ER25 2-16	150	40	42
030.02.16.16	16	ER25 2-16	70	40	42
030.02.16.16-150	16	ER25 2-16	150	40	42
030.02.16.20	20	ER25 2-16	70	40	42
030.02.16.25	25	ER25 2-16	70	40	42
030.02.16.25-150	25	ER25 2-16	150	40	42
030.02.16.32	32	ER25 2-16	80	40	42
030.02.16.32-150	32	ER25 2-16	150	40	42
030.02.16.40	40	ER25 2-16	85	40	42
030.02.16.40-150	40	ER25 2-16	150	40	42
030.02.20.32-150	32	ER32 3-20	150	35	50
030.02.20.20	20	ER32 2-20	70	35	50
030.02.20.20-150	20	ER32 2-20	150	35	50
030.02.20.25	25	ER32 2-20	70	35	50
030.02.20.25-15	25	ER32 2-20	150	35	50
030.02.20.32	32	ER32 3-20	80	35	50
030.02.20.40	40	ER32 2-20	85	35	50
030.02.20.40-150	40	ER32 2-20	150	35	50
030.02.26.40-150	40	ER40 3-26	150	63	63
030.02.26.32	32	ER32 3-26	80	63	63
030.02.26.32-150	32	ER32 3-26	150	63	63
030.02.26.40	40	ER32 3-26	85	63	63

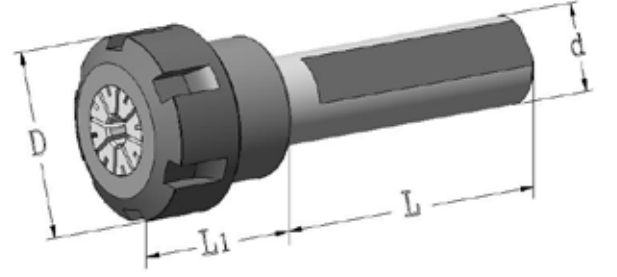

Teslim Şekli : Kapak ile birlikte
Lieferumfang : Inkl. Spannmutter
Included : Clamping nut

Spannfutter mit Zylinderschaft durchbohrt
Collet chuck with cylindrical shank bored through

Sipariş No Bestell Nr. Order Nr.	d	Kapatesi Spannbereich Capacity	L	L1	D
030.02.05.12-100-M	12	ER8 1-5	100	26	12
030.02.05.12-150-M	12	ER8 1-5	150	26	12
030.02.07.16-100-M	16	ER11 1-7	100	24,5	16
030.02.07.16-150-M	16	ER11 1-7	150	24,5	16
030.02.07.20-100-M	20	ER11 1-7	100	24,5	16
030.02.07.20-150-M	20	ER11 1-7	150	24,5	16
030.02.13.16-100-M	16	ER20 1-13	100	44	28
030.02.13.16-150-M	16	ER20 1-13	150	44	28
030.02.13.20-100-M	20	ER20 1-13	100	44	28
030.02.13.20-150-M	20	ER20 1-13	150	44	28
030.02.10.16-150-M	16	ER16 1-10	150	28	22
030.02.10.16-M	16	ER16 1-10	70	28	22
30.02.10.20-M	20	ER16 1-10	70	28	22
030.02.10.20-150-M	20	ER16 1-10	150	28	22

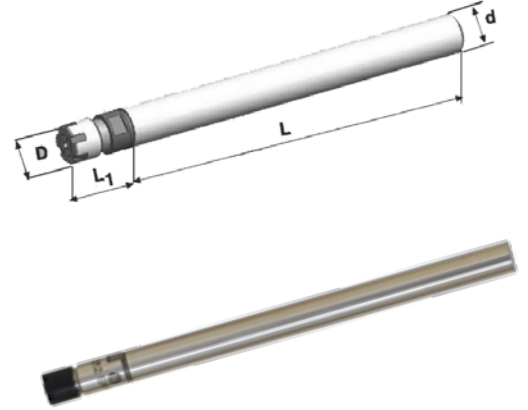

Teslim Şekli : Kapak ile birlikte
Lieferumfang : Inkl. Spannmutter
Included : Clamping nut

Spannzangen CKS
Collets CKS

Sipariş No Bestell Nr. Order Nr.	d	D	L
CKS25 - 6	6	25	53
CKS25 - 8	8	25	53
CKS25 - 10	10	25	53
CKS25 - 12	12	25	53
CKS25 - 16	16	25	53
CKS25 - 20	20	25	53
CKS32 - 6	6	32	65
CKS32 - 8	8	32	65
CKS32 - 10	10	32	65
CKS32 - 12	12	32	65
CKS32 - 16	16	32	65
CKS32 - 20	20	32	65
CKS32 - 25	25	32	65

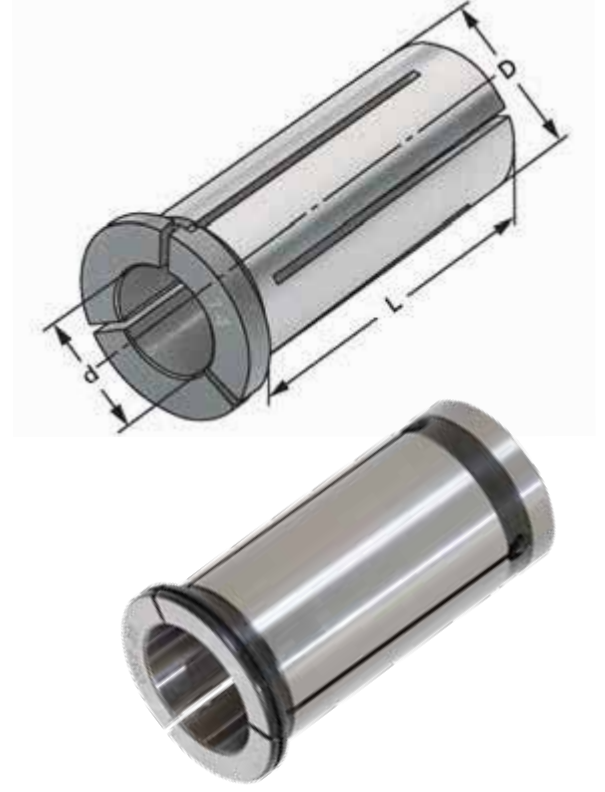

Pensler DIN 6388 B Formu E tipi

415 E

Spannzangen DIN 6388 B
Collets DIN 6388 Form B

Sipariş No Bestell Nr. Order Nr.	d	D	L
415 E-02	2	25,5	40
415 E-03	3	25,5	40
415 E-04	4	25,5	40
415 E-05	5	25,5	40
415 E-06	6	25,5	40
415 E-07	7	25,5	40
415 E-08	8	25,5	40
415 E-09	9	25,5	40
415 E-10	10	25,5	40
415 E-11	11	25,5	40
415 E-12	12	25,5	40
415 E-13	13	25,5	40
415 E-14	14	25,5	40
415 E-15	15	25,5	40
415 E-16	16	25,5	40



Komple Set : Sayfa 76
Komplette Set : Seite 76
Comple Set : Page 76



Spannzangen DIN 6388 B
Collets DIN 6388 Form B

Sipariş No Bestell Nr. Order Nr.	d	D	L
462 E-02	2	35,05	52
462 E-03	3	35,05	52
462 E-04	4	35,05	52
462 E-05	5	35,05	52
462 E-06	6	35,05	52
462 E-07	7	35,05	52
462 E-08	8	35,05	52
462 E-09	9	35,05	52
462 E-10	10	35,05	52
462 E-11	11	35,05	52
462 E-12	12	35,05	52
462 E-13	13	35,05	52
462 E-14	14	35,05	52
462 E-15	15	35,05	52
462 E-16	16	35,05	52
462 E-17	17	35,05	52
462 E-18	18	35,05	52
462 E-19	19	35,05	52
462 E-20	20	35,05	52
462 E-21	21	35,05	52
462 E-22	22	35,05	52
462 E-23	23	35,05	52
462 E-24	24	35,05	52
462 E-25	25	35,05	52

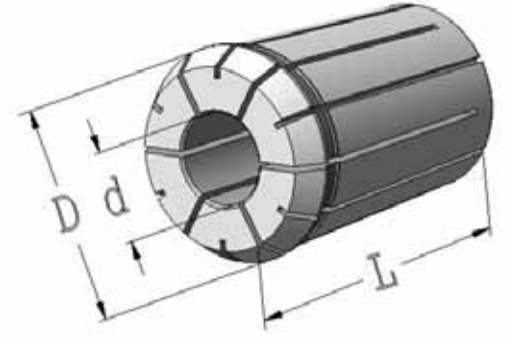

Komple Set : Sayfa 76
Komplette Set : Seite 76
Comple Set : Page 76

Spannzangen DIN 6388 B
Collets DIN 6388 Form B

Sipariş No Bestell Nr. Order Nr.	d	D	L
467 E-03	3	43,7	60
467 E-04	4	43,7	60
467 E-05	5	43,7	60
467 E-06	6	43,7	60
467 E-07	7	43,7	60
467 E-08	8	43,7	60
467 E-09	9	43,7	60
467 E-10	10	43,7	60
467 E-11	11	43,7	60
467 E-12	12	43,7	60
467 E-13	13	43,7	60
467 E-14	14	43,7	60
467 E-15	15	43,7	60
467 E-16	16	43,7	60
467 E-17	17	43,7	60
467 E-18	18	43,7	60
467 E-19	19	43,7	60
467 E-20	20	43,7	60
467 E-21	21	43,7	60
467 E-22	22	43,7	60
467 E-23	23	43,7	60
467 E-24	24	43,7	60
467 E-25	25	43,7	60
467 E-26	26	43,7	60
467 E-27	27	43,7	60
467 E-28	28	43,7	60
467 E-29	29	43,7	60
467 E-30	30	43,7	60
467 E-31	31	43,7	60
467 E-32	32	43,7	60

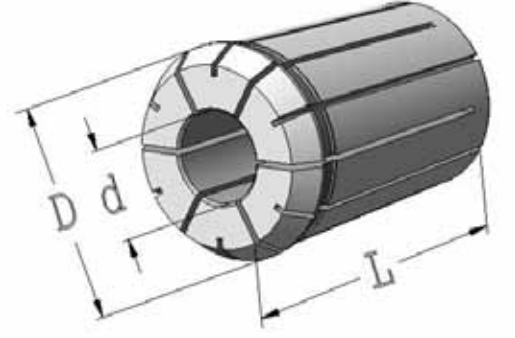

Komple Set : Sayfa 76
Komplette Set : Seite 76
Comple Set : Page 76



Spannzangen System ER DIN 6499
Collets System ER DIN 6499

Sipariş No Bestell Nr. Order Nr.	d	D	L
4004 E-01	1	8,5	13,6
4004 E-1,5	1,5	8,5	13,6
4004 E-02	2	8,5	13,6
4004 E-2,5	2,5	8,5	13,6
4004 E-03	3	8,5	13,6
4004 E-3,5	3,5	8,5	13,6
4004 E-04	4	8,5	13,6
4004 E-4,5	4,5	8,5	13,6
4004 E-5	5	8,5	13,6

Komple Set : Sayfa 76
Komplette Set : Seite 76
Comple Set : Page 76

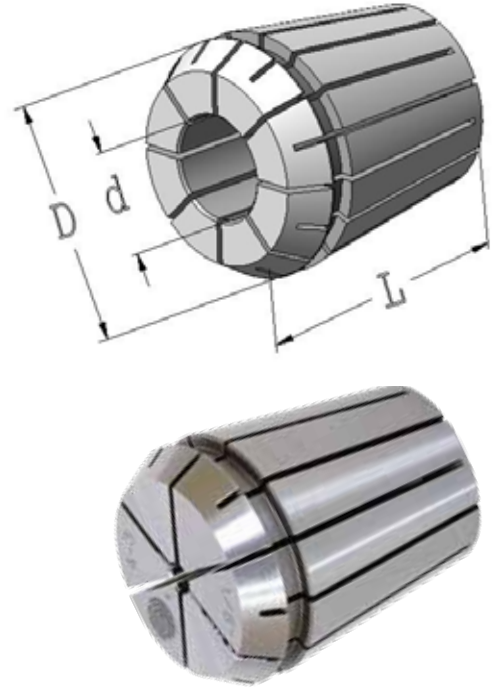

Spannzangen System ER DIN 6499
Collets System ER DIN 6499

Sipariş No Bestell Nr. Order Nr.	d	D	L
4008 E-01	1	11,5	18
4008 E-1,5	1,5	11,5	18
4008 E-02	2	11,5	18
4008 E-2,5	2,5	11,5	18
4008 E-03	3	11,5	18
4008 E-3,5	3,5	11,5	18
4008 E-04	4	11,5	18
4008 E-4,5	4,5	11,5	18
4008 E-5	5	11,5	18
4008 E-5,5	5,5	11,5	18
4008 E-06	6	11,5	18
4008 E-6,5	6,5	11,5	18
4008 E-07	7	11,5	18

Komple Set : Sayfa 76
Komplette Set : Seite 76
Comple Set : Page 76

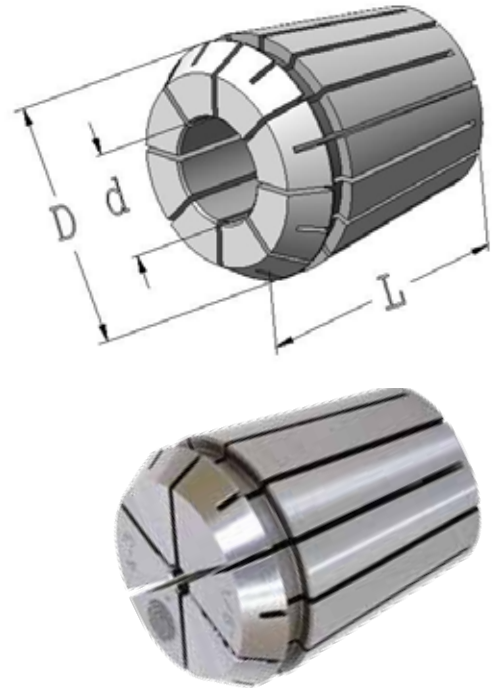

Spannzangen System ER DIN 6499
Collets System ER DIN 6499

Sipariş No Bestell Nr. Order Nr.	d	D	L
426 E-01	1	17	27,5
426 E-02	2	17	27,5
426 E-03	3	17	27,5
426 E-04	4	17	27,5
426 E-05	5	17	27,5
426 E-06	6	17	27,5
426 E-07	7	17	27,5
426 E-08	8	17	27,5
426 E-09	9	17	27,5
426 E-10	10	17	27,5

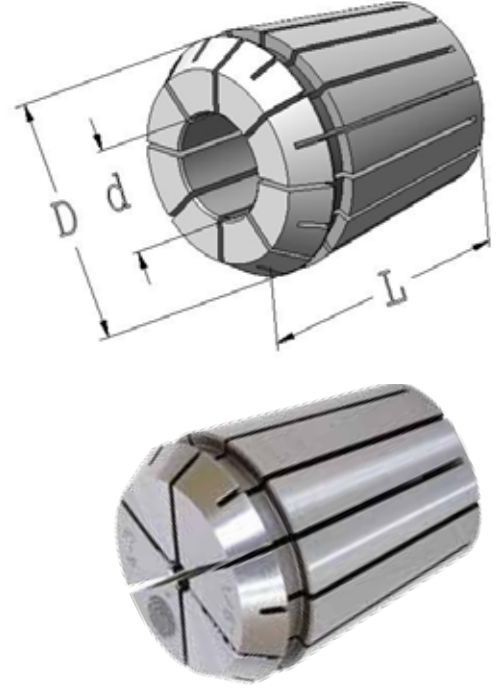

Komple Set : Sayfa 76
Komplette Set : Seite 76
Comple Set : Page 76

Spannzangen System ER DIN 6499
Collets System ER DIN 6499

Sipariş No Bestell Nr. Order Nr.	d	D	L
428 E-02	2	21	31,5
428 E-02	3	21	31,5
428 E-04	4	21	31,5
428 E-05	5	21	31,5
428 E-06	6	21	31,5
428 E-07	7	21	31,5
428 E-08	8	21	31,5
428 E-09	9	21	31,5
428 E-10	10	21	31,5
428 E-11	11	21	31,5
428 E-12	12	21	31,5
428 E-13	13	21	31,5

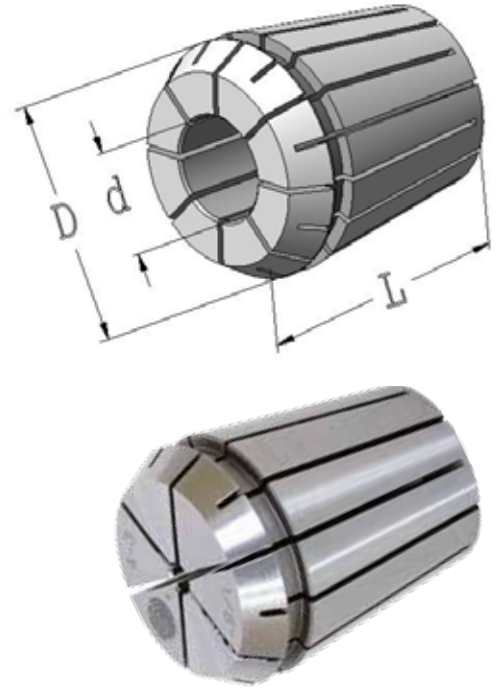

Komple Set : Sayfa 76
Komplette Set : Seite 76
Comple Set : Page 76

Spannzangen System ER DIN 6499
Collets System ER DIN 6499

Sipariş No Bestell Nr. Order Nr.	d	D	L
430 E-02	2	26	34
430 E-03	3	26	34
430 E-04	4	26	34
430 E-05	5	26	34
430 E-06	6	26	34
430 E-07	7	26	34
430 E-08	8	26	34
430 E-09	9	26	34
430 E-10	10	26	34
430 E-11	11	26	34
430 E-12	12	26	34
430 E-13	13	26	34
430 E-14	14	26	34
430 E-15	15	26	34
430 E-16	16	26	34



Komple Set : Sayfa 76
Komplette Set : Seite 76
Comple Set : Page 76

Spannzangen System ER DIN 6499
Collets System ER DIN 6499

Sipariş No Bestell Nr. Order Nr.	d	D	L
470 E-02	2	33	40
470 E-03	3	33	40
470 E-04	4	33	40
470 E-05	5	33	40
470 E-06	6	33	40
470 E-07	7	33	40
470 E-08	8	33	40
470 E-09	9	33	40
470 E-10	10	33	40
470 E-11	11	33	40
470 E-12	12	33	40
470 E-13	13	33	40
470 E-14	14	33	40
470 E-15	15	33	40
470 E-16	16	33	40
470 E-17	17	33	40
470 E-18	18	33	40
470 E-19	19	33	40
470 E-20	20	33	40

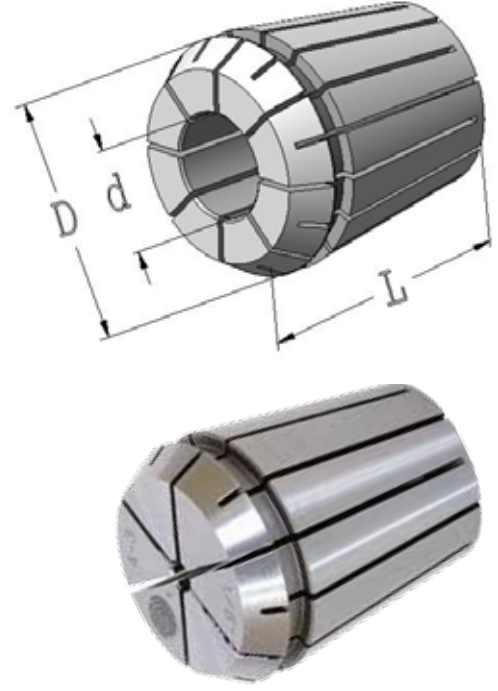

Komple Set : Sayfa 76
Komplette Set : Seite 76
Comple Set : Page 76

Spannzangen System ER DIN 6499
Collets System ER DIN 6499

Sipariş No Bestell Nr. Order Nr.	d	D	L
472 E-03	3	41	46
472 E-04	4	41	46
472 E-05	5	41	46
472 E-06	6	41	46
472 E-07	7	41	46
472 E-08	8	41	46
472 E-09	9	41	46
472 E-10	10	41	46
472 E-11	11	41	46
472 E-12	12	41	46
472 E-13	13	41	46
472 E-14	14	41	46
472 E-15	15	41	46
472 E-16	16	41	46
472 E-17	17	41	46
472 E-18	18	41	46
472 E-19	19	41	46
472 E-20	20	41	46
472 E-21	21	41	46
472 E-22	22	41	46
472 E-23	23	41	46
472 E-24	24	41	46
472 E-25	25	41	46
472 E-26	26	41	46

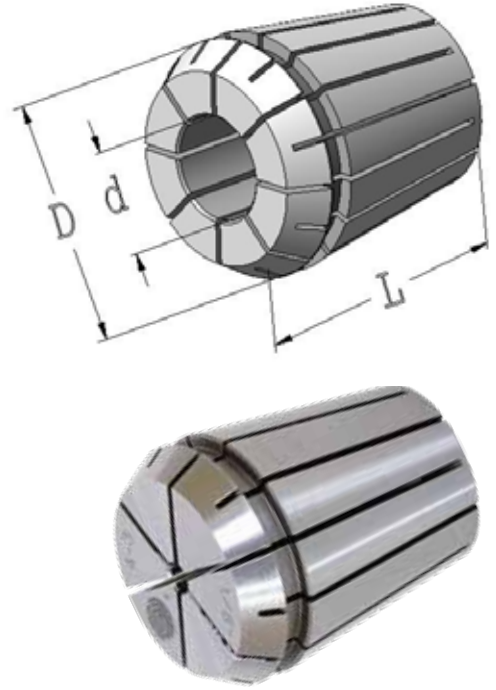

Komple Set : Sayfa 76
Komplette Set : Seite 76
Comple Set : Page 76

Spannzangensatz im Koffer
Collets Set in box

Sipariş No Bestell Nr. Order Nr.	Cinsi Abmessung Size	B x H x L
415 E- S	415 E (15 St.)	180 x 50 x 235
462 E- S	462 E (16 St.)	210 x 75 x 250
467 E- S	467 E (16 St.)	225 x 80 x 270
426 E- S	426 E (ER 16) (10 St.)	45 x 110 x 115
430 E- S	430 E (ER 25) (15 St.)	185 x 50 x 235
470 E- S	470 E (ER 32) (18 St.)	210 x 75 x 250
472 E- S	472 E (ER 40) (23 St.)	275 x 80 x 340



Sipariş No Bestell Nr. Order Nr.	Cinsi Abmessung Size
415 E (15 St.)	2-3-4-5-6-7-8-9-10-11-12-13-14-15-16
462 E (16 St.)	4-5-6-7-8-9-10-11-12-13-14-15-16-18-20-22-24-25
467 E (16 St.)	5-6-7-8-9-10-12-14-16-18-20-22-24-25-28-30-32
426 E (ER 16) (10 St.)	1-2-3-4-5-6-7-8-9-10
430 E (ER 25) (15 St.)	2-3-4-5-6-7-8-9-10-11-12-13-14-15-16
470 E (ER 32) (18 St.)	3-4-5-6-7-8-9-10-11-12-13-14-15-16-17-18-19-20
472 E (ER 40) (23 St.)	4-5-6-7-8-9-10-11-12-13-14-15-16-17-18-19-20-21-22-23-24-25-26

Pens kapağı bilyeli tip DIN 6388 D

Spannmutter OZ DIN 6388 D kugellagırte Ausführung
Clamping nuts OZ DIN 6388 D ball-bearing version

Sipariř No Bestell Nr. Order Nr.	Cinsi Abmessung Size	D	Diř Gewinde Tap
130.70.16	2 - 16	43	M33 x 1,5
130.71.25	2 - 25	60	M48 x 2
130.72.32	3 - 32	72	M60 x 2,5

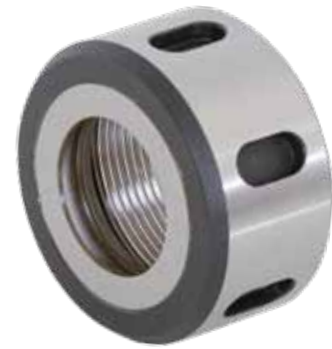
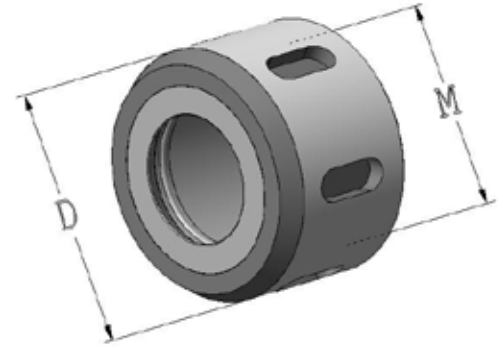

Pens kapağı ER tip DIN 6499

Spannmutter ER DIN 6499
Clamping nuts ER DIN 6499

Sipariř No Bestell Nr. Order Nr.	Cinsi Abmessung Size	D	Diř Gewinde Tap
131.70.05.M	ER 8	12	M10 x 0,75
131.71.07.M	ER 11	16	M13 x 0,75
131.80.10.M	ER 16	22	M19 x 1
131.72.10	ER 16	32	M22 x 1,5
131.81.16.M	ER 20	28	M24 x 1
131.72.13	ER 20	35	M25 x 1,5
131.81.16	ER 25	42	M32 x 1,5
131.82.20	ER 32	50	M40 x 1,5
131.83.26	ER 40	63	M50 x 1,5

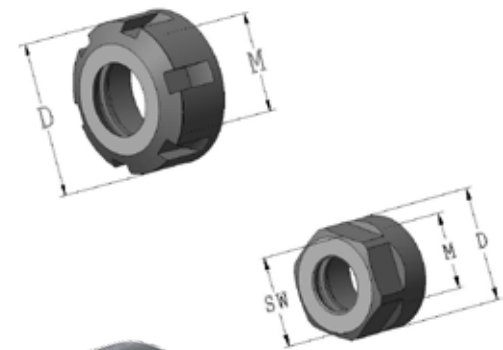

E Tipi Ay anahtar DIN 1810 A

Hakenschlüssel DIN 1810 A für OZ - Spannmuttern / EKS
Wrench DIN 1810 A

Sipariş No Bestell Nr. Order Nr.	Cinsi Abmessung Size	D
140.70.16	2 -16(415 E)	40 - 42
140.71.25	2 - 25(462 E)	58 - 62
140.72.32	3 - 32(467 E)	68 - 75
140.73.25	CKS 25 6-25	58 - 62
140.73.32	CKS 32 6-32	68 - 75



ER tipi anahtar

Spannschlüssel für ER Spannmuttern
Wrench ER

Sipariş No Bestell Nr. Order Nr.	Cinsi Abmessung Size	D
141.80.10	1 -10 (ER 16)	32
141.72.13	1 -13 (ER 20)	35
141.81.16	2 - 16 (ER 25)	42
141.82.20	2- 20 (ER 32)	50
141.83.26	2 -26 (ER 40)	63



ER tipi anahtar mini

Spannschlüssel ER Mini
Wrench ER Mini

Sipariş No Bestell Nr. Order Nr.	Cinsi Abmessung Size	D
141.70.05	1 - 5 (ER 8)	12
141.71.07	1 -7 (ER 11)	16
141.80.10 m	1- 10 (ER 16)	22
141.72.13 m	1 -13 (ER 20)	30





Anzugsbolzen
Pull studs

Sipariş No Bestell Nr. Order Nr.	Cinsi Abmessung Size	D	M	I	L	h
002.40.16	M16	25	M16	28	53	13,7
003.50.24	M24	39,2	M24	40	65	13



Anzugsbolzen
Pull studs

Sipariş No Bestell Nr. Order Nr.	Cinsi Abmessung Size	D	M	I	L	h	İçten delikli Durchgangsbohrung Through hole \varnothing	O-Ring X
005.30.16	M12	13	M12	20	44	19	-	X
006.40.16	M16	19	M16	28	54	20	$\varnothing 7$	X
016.40.16	M16	19	M16	28	54	20	-	X
007.50.24	M24	28	M24	40	74	25	$\varnothing 11,5$	X
017.50.24	M24	28	M24	40	74	25	-	X



Anzugsbolzen
Pull studs

Sipariş No Bestell Nr. Order Nr.	Cinsi Abmessung Size	D	M	I	L	h	İçten delikli Durchgangsbohrung Through hole \varnothing
016.40.16	M16	19	M16	25	41,25	11,17	$\varnothing 7$
016.40.16.0	M16	19	M16	25	44,08	14	$\varnothing 7$
017.50.24	M24	29	M24	40	65	17,95	$\varnothing 10$



Anzugsbolzen
Pull studs

Sipariş No Bestell Nr. Order Nr.	Cinsi Abmessung Size	D	M	I	L	h	İçten delikli Durchgangsbohrung Through hole \emptyset
010.30.45	M12-45	11	M12	20	43	18	-
011.40.45	M16-45	15	M16	25	60	28	-
012.50.45	M24-45	23	M24	40	85	35	-
010.30.60	M12-60	11	M12	20	43	18	-
011.40.60	M16-60	15	M16	25	60	28	-
012.50.60	M24-60	23	M24	40	85	35	-
010.30.90	M12-90	11	M12	20	43	18	-
011.40.90	M16-90	15	M16	25	60	28	-
012.50.90	M24-90	23	M24	40	85	35	-
111.40.45	M16-45	15	M16	25	60	28	$\emptyset 3$
112.50.45	M24-45	23	M24	40	85	35	$\emptyset 6$
111.40.60	M16-60	15	M16	25	60	28	$\emptyset 3$
112.50.60	M24-60	23	M24	40	85	35	$\emptyset 6$
111.40.90	M16-90	15	M16	25	60	28	$\emptyset 3$
112.50.90	M24-90	23	M24	40	85	35	$\emptyset 6$

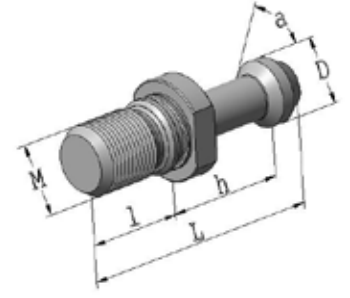

ER Tipi DIN 6499 / Vidalı pens tutucuları

DIN 6499 ER Spannzangen aufnahme mit schraube adaptation
DIN 6499 ER collet chucks with threaded adaptations

Sipariş No Bestell Nr. Order Nr.	Cinsi Abmessung Size	M	L1	L2	D3	T
035.02.07.M10	ER11	M10	27	20	16	15
035.02.07.M12	ER11	M12	27	25	16	17
035.02.10.M10	ER16	M10	38	20	22	17
035.02.10.M12	ER16	M12	37	22	22	17
035.02.10.M16	ER16	M16	36	25	28	25
035.02.13.M16	ER20	M16	45	25	34	25
035.02.16.M16	ER25	M16	44	25	42	28

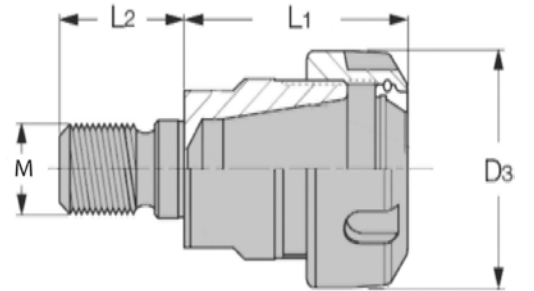

Vidalı TIP Frezeler için Silindirik Şaftlı takım tutucular

Fräsdorne für Aufschraubfräser Zylinderschäfte DIN 1835-B
Milling Cutter Arbors for Screw-on type Milling Cutters

Sipariş No Bestell Nr. Order Nr.	D	M	d1	d2	d3	A	L
034.24.12.5,5-20	12	5	5,5	10	12	20	65
034.24.16.8,5-40	20	6	6,5	10	18	25	75
034.24.20.6,5-25	20	6	6,5	10	18	50	100
034.24.20.6,5-50	20	6	6,5	10	18	75	125
034.24.20.6,5-75	16	8	8,5	13	16	40	88
034.24.20.8,5-25	20	8	8,5	13	18	25	75
034.24.20.8,5-50	20	8	8,5	13	18	50	100
034.24.20.8,5-75	20	8	8,5	13	18	75	125
034.24.20.10,5-25	20	10	10,5	18	18	25	75
034.24.20.10,5-50	20	10	10,5	18	18	50	100
034.24.20.10,5-75	20	10	10,5	18	18	75	125
034.24.20.10,5-97	20	10	10,5	18,5	20	97	152
034.24.25.12,5-25	25	12	12,5	21	25	25	81
034.24.25.12,5-40	25	12	12,5	23	25	40	101
034.24.25.12,5-75	25	12	12,5	21	25	75	131
034.24.25.12,5-109	25	12	12,5	23	25	109	170
034.24.25.12,5-125	25	12	12,5	21	25	125	181
034.24.32.17.-25	32	16	17	29	32	25	85
034.24.32.17-40	32	16	17	30	32	40	105
034.24.32.17-75	32	16	17	29	32	75	135
034.24.32.17-125	32	16	17	29	32	125	185



Vidalı Tip Frezeler için ara adaptör

Verlängerungen für Aufschraubfräser
Extension for milling cutter arbors

Sipariş No Bestell Nr. Order Nr.	D	M	d1	L
033.24.13,5-M8	13,5	M8	8,5	30
033.24.18.5-M10	18.5	M10	10,5	35
033.24.23-M12	23	M12	12,5	40
033.24.30-M16	30	M16	17	40

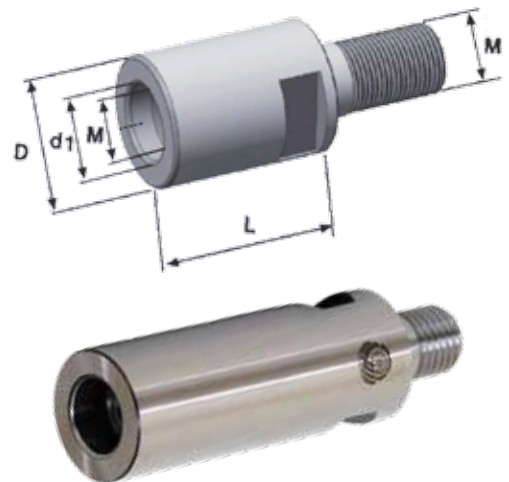

Silindirik şaftlı kılavuz başlıkları

Gewindescheid-Schnellwechselfutter mit Längenausgleich auf Druck und zug für Zylinderschaft
Quick-change tapping chucks with length compensation for cylindrical shank

Sipariş No Bestell Nr. Order Nr.	d	Kapasite Spannbereich Capacity	A	D
032.22.12.25	25	KCB 01 M3 - M14	50	36,5
032.22.24.25	25	KCB 02 M5 - M24	50	53,5
033.22.12.32	32	KCB 01 M3 - M14	61	36,5
033.22.24.32	32	KCB 02 M5 - M24	61	53,5
034.22.12.40	40	KCB 01 M3 - M14	68	36,5
034.22.24.40	40	KCB 02 M5 - M24	68	53,5



Delik katerleri redüksiyonu

Reduzierbuchse für Bohrstangenhalter
Reduction bushes for boring bar holder

Sipariş No Bestell Nr. Order Nr.	d	d1	L
040.25.06	25	6	50
040.25.08	25	8	50
040.25.10	25	10	50
040.25.12	25	12	50
040.25.16	25	16	50
040.25.20	25	20	50
041.32.06	32	6	70
041.32.08	32	8	70
041.32.10	32	10	70
041.32.12	32	12	70
041.32.16	32	16	70
041.32.20	32	20	70
041.32.25	32	25	70
042.40.06	40	6	80
042.40.08	40	8	80
042.40.10	40	10	80
042.40.12	40	12	80
042.40.16	40	16	80
042.40.20	40	20	80
042.40.25	40	25	80
042.40.32	40	32	80

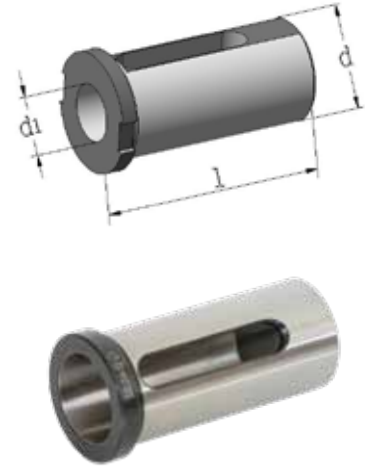

Einsätze mit Rutschkupplung
Tapping collets with Clutch

Sipariş No Bestell Nr. Order Nr.	D	d	L1	M	DIN	Şaft Shaft	Kare Vierk Square
080.65.228	32	19	25	M2	371	2,8	2,1
080.65.2529	32	19	25	M2,5	371	2,8	2,1
080.65.335	32	19	25	M3	371	3,5	2,7
080.65.354	32	19	25	M3,5	371	4	3,0
080.65.445	32	19	25	M4	371	4,5	3,4
080.65.5649	32	19	25	M5	371	6,0	4,9
080.65.6649	32	19	25	M6	371	6,0	4,9
080.65.88	32	19	25	M8	371	8,0	6,2
080.65.107	32	19	25	M10	371	7,0	5,5
080.65.1010	32	19	25	M10	371	10,0	8,0
080.65.129	32	19	25	M12	376	9,0	7,0
080.65.14119	32	19	25	M14	376	11	9,0

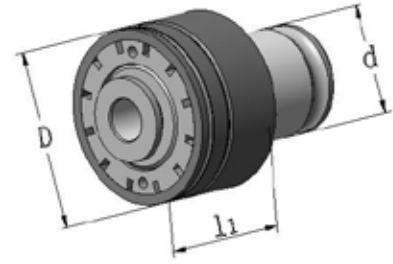

Klavuz tutucu emniyetsiz

M3 - M14

Einsätze ohne Rutschkupplung
Tapping collets without Clutch

Sipariş No Bestell Nr. Order Nr.	D	d	L1	Şaft Shaft	Kare Vierk Square
080.66.2821	30	19	5	2,8	2,1
080.66.3527	30	19	5	3,5	2,7
080.66.4534	30	19	5	4,5	3,4
080.66.43	30	19	5	4,0	3,0
080.66.649	30	19	5	6,0	4,9
080.66.755	30	19	5	7,0	5,5
080.66.862	30	19	5	8,0	6,2
080.66.97	30	19	5	9,0	7,0
080.66.108	30	19	5	10	8,0
080.66.119	30	19	5	11	9,0

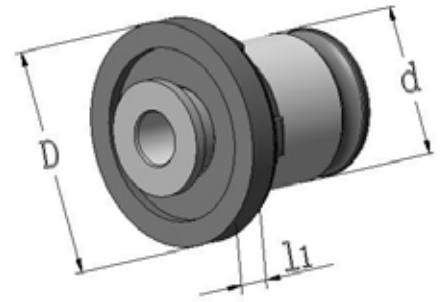

Einsätze mit Rutschkupplung
Tapping collets with Clutch

Sipariş No Bestell Nr. Order Nr.	D	d	L1	M	DIN	Şaft Schaft Shaft	Kare Vierk Square
081.65.5649	50	31	31	M5	371	6	4,9
081.65.6649	50	31	31	M6	371	6	4,9
081.65.88	50	31	31	M8	371	8	6,2
081.65.107	50	31	31	M10	376	7	5,5
081.65.1010	50	31	31	M10	371	10	8,0
081.65.129	50	31	31	M12	376	9	7,0
081.65.14119	50	31	31	M14	376	11	9,0
081.65.1612	50	31	31	M16	376	12	9,0
081.65.181414	50	31	31	M18	376	14	11,0
081.65.2016	50	31	31	M20	376	16	12,0
081.65.2218145	50	31	31	M22	376	18	14,5

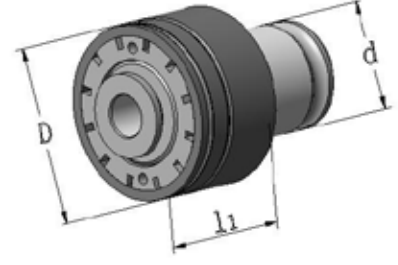

Klavuz tutucu emniyetsiz

M5 - M22

Einsätze ohne Rutschkupplung
Tapping collets without Clutch

Sipariş No Bestell Nr. Order Nr.	D	d	L1	Şaft Schaft Shaft	Kare Vierk Square
081.66.649	48	31	6	6	4,9
081.66.755	48	31	6	7	5,5
081.66.862	48	31	6	8	6,2
081.66.97	48	31	6	9	7,0
081.66.108	48	31	6	10	8,0
081.66.119	48	31	6	11	9,0
081.66.129	48	31	6	12	9,0
081.66.1411	48	31	6	14	11,0
081.66.1612	48	31	6	16	12,0
081.66.18145	48	31	6	18	14,5

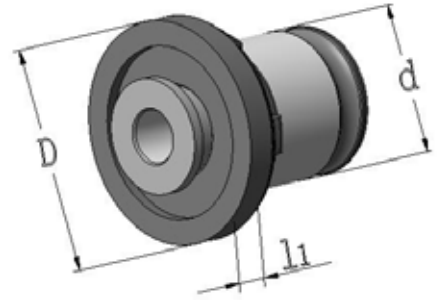

Montaj aparatı çelik sağa ve sola 90° dönebilen

Montage block aus Stahl, schwenkbar
Universal assembly block steel

Sipariş No Bestell Nr. Order Nr.	Cinsi Abmessung Size	L	H	B
121.61	SK 40	130	136	64
122.61	SK 50	170	170	72
020.61	VDI 30	130	121	64
021.61	VDI 40	130	136	64
190.61	HSK 63	130	136	64
191.61	HSK 100	170	170	72

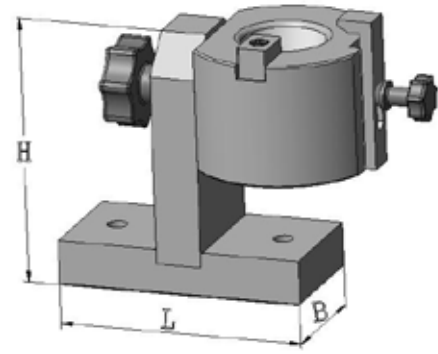

Montaj aparatı Alüminyum

Montage block aus Aluminium
Tightening fixtures Aluminium

Sipariş No Bestell Nr. Order Nr.	Cinsi Abmessung Size	L	H	B
121.60	SK 40	160	75	62
122.60	SK 50	180	155	99

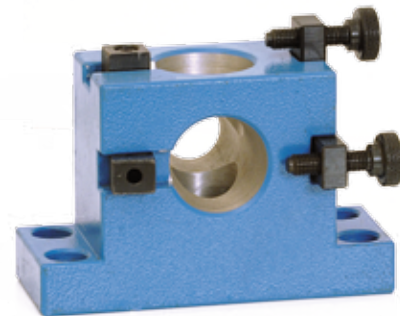
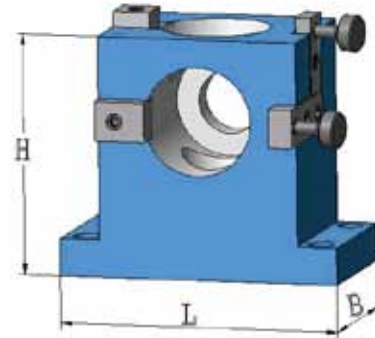

Tarama başlık sıkma civatası DIN 6367

Fräseranzugschrauben DIN 6367
Drawn in bolt DIN 6367

Sipariş No Bestell Nr. Order Nr.	Cinsi Abmessung Size	M	D	K	L
150.32.16	16	M8	20	6	16
150.32.22	22	M10	28	7	18
150.32.27	27	M12	35	8	22
150.32.32	32	M16	42	9	26
150.32.40	40	M20	52	10	30
150.32.50	50	M24	63	12	36

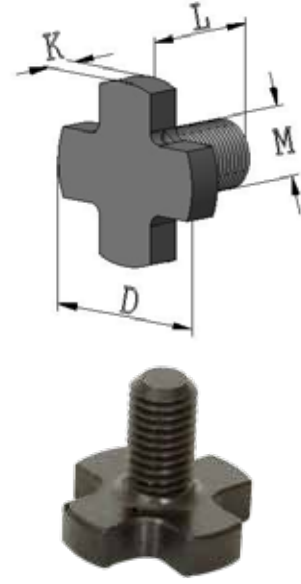

Tırnaklı pul DIN 6366

Mitnehmerringe DIN 6366
Clutch drive rings to DIN 6366

Sipariş No Bestell Nr. Order Nr.	d	D	a	b	h
150.30.16	16	32	10	8	5
150.30.22	22	40	12	10	5,6
150.30.27	27	48	12	12	6,3
150.30.32	32	58	14	14	7
150.30.40	40	70	14	16	8



Delik Kateri Redüksiyonu EZ Tutucular için

Reduzierbuchse für Bohrstangenhalter
Reduction bushes for boring bar holder

Sipariş No Bestell Nr. Order Nr.	Cinsi Abmessung Size
040.25	ø 6 - 20
041.32	ø 6 - 25
042.40	ø 6 - 32

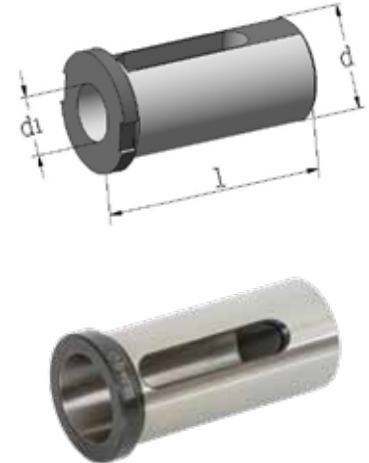

Hidrolik pens aynası

Kraftspannfutter DIN 55021 / 22 / 27 / 28
Power chucks DIN 55021

Sipariş No Bestell Nr. Order Nr.	DIN 55021 22/27/28					Pens Spanzagen collets Pincas	I	L
	D	D2	D3	D1	d			
110.90.05	135	104,8	5	100	4-42	173 E	104	132
111.90.06	165	133,4	6	118	4-42	173 E	104	134
112.90.06	165	133,4	6	122	6-60	185 E	117	151
113.90.08	208	171,4	8	138	6-60	185 E	114	154

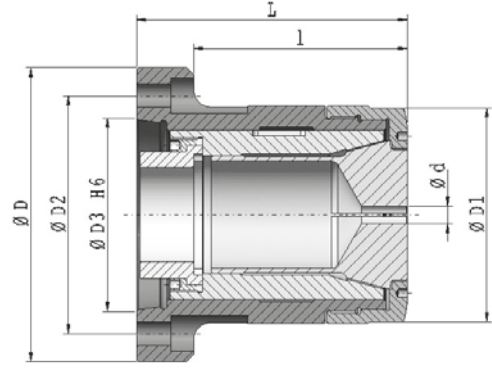

Hidrolik pens aynası

Kraftspannfutter DIN 55021 / 22 / 27 / 28
Power chucks DIN 55021

Sipariş No Bestell Nr. Order Nr.	Profil	d	d1	d2	D	I	L	α	β
161.26.04	○	2-26	32	34	45	67	75	15°	10°
161.26.AK4	◇	4-22	32	34	45	67	75	15°	10°
161.26.K04	□	4-18	32	34	45	67	75	15°	10°
163.30.04	○	2-30	35	38	48	72	80	15°	10°
163.30.AK6	◇	4-24	35	38	48	72	80	15°	10°
163.30.K06	□	5-20	35	38	48	72	80	15°	10°
171.36.04	○	5-36	42	42	55	85	94	15°	10°
171.36.AK4	◇	10-30	42	42	55	85	94	15°	10°
171.36.K04	□	10-28	42	42	55	85	94	15°	10°
173.42.04	○	4-42	48	50	60	85	94	15°	10°
173.42.AK6	◇	6-36	48	50	60	85	94	15°	10°
173.42.K06	□	6-28	48	50	60	85	94	15°	10°
185.60.06	○	6-60	66	73	84	101	110	15°	10°
185.60.AK6	◇	8-50	66	73	84	101	110	15°	10°
185.60.K06	□	8-40	66	73	84	101	110	15°	10°

